

General Specifications

AXR Two-wire Magnetic Flowmeter Integral Flowmeter



GS 01E30D01-01EN

[Style: S2]

■ GENERAL DESCRIPTION

The ADMAG AXR two-wire magnetic flowmeter can be installed in the two-wire system without any AC power source, thus drastically reducing the initial instrumentation cost.

The ADMAG AXR is the world's first two-wire magnetic flowmeter which employs the fluid noise free "Dual Frequency Excitation Method," achieving excellent stability for instrumentation.

Like the AXF four-wire magnetic flowmeter series, the ADMAG AXR has user-friendly functions such as a full dot-matrix LCD indicator, electrode adhesion level diagnosis function, and a multi-lingual display. The magnet switches can be used for checking and setting parameters without opening the case cover.

Note: The "Dual Frequency Excitation Method" is Yokogawa's unique technology.



■ FEATURES

● High Performance and Excellent Functionality

Dual Frequency Excitation Method

The "Dual Frequency Excitation Method" combines two strengths: stability in flow measurement due to low frequency excitation and high noise resistance due to high frequency excitation. Therefore, the method is strong against fluctuations of fluid condition and is ideal for stable measurement.

High Accuracy

The ADMAG AXR performs 0.5% of rate under normal flowrate conditions.

Electric Noise Resistance

The ADMAG AXR offers electric noise resistance compared with the four-wire magnetic flowmeter.

High Reliability

The ADMAG AXR complies with SIL2 for safety requirement. The ADMAG AXR has SIL2 capability for single flowmeter use and SIL3 capability for dual flowmeter use.

● Reducing the Instrumentation Cost

Reducing the Wiring Cost

The two-wire system reduces the wiring cost drastically.

Direct Connection with the DCS

AC power sources are not necessary. The ADMAG AXR can be connected with almost all distributors, signal conditioner cards, and input modules.

Energy Saving

Compared with four-wire magnetic flowmeters, the ADMAG AXR can drastically decrease power consumption.

● User-friendly Functionality

Enhanced Diagnostic Function

By checking the level of the insulating substance on the electrodes, it is possible to determine when maintenance is required.

Results of mean flow measurement during a given period, etc. can be checked by using parameters.

Clear and Versatile Indications

The full dot-matrix LCD indicator facilitates various displays such as one to three lines and multi-lingual display.

In an alarm condition, a full description of the countermeasure is indicated.

Parameter Setting

Magnet switches and push switches are employed.

Magnet switches enable parameters to be set without opening the case cover in the hazardous area.

Various Output Signals

In addition to the current output, one output can be selected among pulse, alarm, and status. Various functions such as multiple-range, forward and reverse flow measurement, and flow rate upper/lower limit alarm are achieved. The pulse output is a high speed of 10,000 pps (pulses per second).

CONTENTS

General description, Features	P.1
Standard Specifications	P.2
Hazardous Area Classification	P.7
Standard Performance	P.9
Normal Operating Conditions	P.11
Cautions for Installation	P.12
Accessories	P.13
Terminal Configuration and Terminal Wiring	P.13
Wiring Example	P.14
Model and Suffix Code	P.21
Optional Specifications	P.25
External Dimensions	P.28
Sizing Data	P.35
Ordering Information	P.36

STANDARD SPECIFICATIONS

Converter

The contents of (*1) and (*2) described in the converter specifications are follows.

- *1: One output can be selected from pulse, alarm, or status through the parameter setting.
- *2: For models without an indicator, the configuration tool (Such as handheld terminal or FieldMate, etc.) is necessary to set or change parameters.

Excitation Method:

- Dual frequency excitation: Size 25 to 200 mm (1 to 8 in.)

Output Signals:

- Current output and digital output can be carried out simultaneously.
Read "WIRING EXAMPLE".
- Current output: 4 to 20 mA DC, two-wire system
Output range: 3.8 to 20.5 mA (-1.25 to 103.13%)
- Digital output (*1):
Transistor contact output, open collector
Contact rating: 30 V DC, 120 mA DC
Low level: 0 to 2 V DC (Read Figure 1)

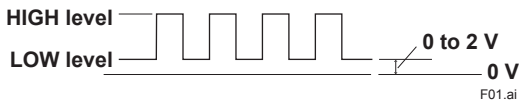

Figure 1 High and Low levels (transistor contact output)

Current Output Status at System Alarms (Burnout)

- Up-scale: 110%, 21.6 mA DC or more (standard)
- Down-scale: -5%, 3.2 mA DC or less

Supply Voltage:

- 14.7 to 42 V DC for general-purpose use and explosion proof type
- 14.7 to 32 V DC for lightning protector (optional code A)

Note 1: Supply voltage means the voltage necessary to provide between the power terminals of the magnetic flowmeter.

Note 2: Connecting with the commercial AC power supply will damage the flowmeter. Be sure to use the DC power supply in the predetermined range.

Note 3: The ADMAG AXR can be connected with almost all distributors, signal conditioner cards, and I/O modules except certain devices.

Read the following table for Yokogawa's devices, choose an appropriate connecting device and the corresponding length of cable.

For devices other than those in the table, decide on the connection by reading the supply voltage specifications and the description in "WIRING EXAMPLE".

Connecting device		Maximum length of cable (rough guideline)	
Name	Model	Cable with cross section of 2 mm ²	Cable with cross section of 1.25 mm ²
Signal Conditioner Card	EA1 EA2	2 km	2 km
I/O Module	AAM11 AAM11B	2 km	2 km
Analog I/O Module (for FIO)	AAI143	2 km	2 km
	AAI141 AAI841 AAI135 AAI835	Not applicable	Not applicable
	SAI143	1.4 km	0.8 km
	SDBT SDBS	2 km	2 km
JUXTA	VJA1 VJA4 VJA7	2 km	2 km

Communication Requirement:

BRAIN

Communication Signal:
BRAIN communication signal (superimposed on 4 to 20 mA DC signals)

Conditions of Communication Line:

Supply Voltage: 20.6 to 42 V DC
Load Resistance: 250 to 600 Ω (including cable resistance)

Read Figure 2.

Communication Distance: Up to a distance of 2 km when a CEV cable is used

Read "WIRING EXAMPLE".

Load Capacitance: 0.22 μF or less

Load Inductance: 3.3 mH or less

Distance from other Power Line: 15 cm (6 in.) or more (Avoid parallel wiring.)

Input Impedance of Communicating Device:

10 kΩ or more at 2.4 kHz

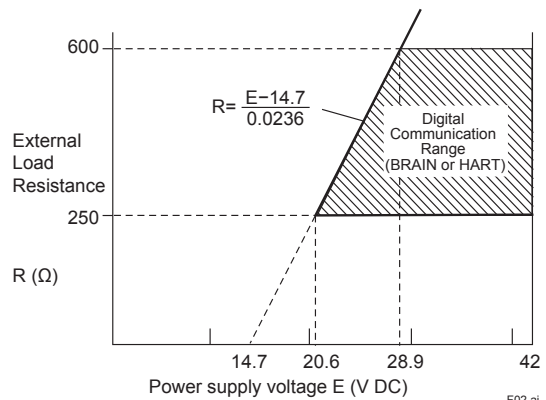

Figure 2 Relationship Between Power Supply Voltage And External Load Resistance

HART

Communication Signal:

HART communication signal (superimposed on 4 to 20 mA DC signals)

Note: HART is a registered trademark of the FieldComm Group.

Conditions of Communication Line:

Supply Voltage: 20.6 to 42 V DC

Load Resistance: 250 to 600 Ω (including cable resistance)
 Read Figure 2.
 HART Protocol Revision:
 HART protocol revision can be selected from 5 or 7 when ordering. ("-J" only)
 The protocol revision can be changed by user configuration.
 The HART protocol revision at the time of shipment is shown by the last number at the serial number column of the name plate.
 Note: Protocol revision supported by HART configuration tool must be the same or higher than that of AXR.

Selection of HART 5/ HART 7

Output Signal Code		-E	-J	
Ordering Information		-	Specify "5"	Specify "7"
HART Protocol Revision		HART 5		HART 7
Selection guide	Requirement for HART 7 functionality	NO		YES Be sure to confirm the protocol revision of the HART configuration tool shown in Note 2.
	Other conditions	Not available to switch to HART 7 protocol after delivery.	Available to switch to HART 7 protocol after delivery by user-configuration.	Available to switch to HART 5 protocol after delivery by user-configuration.
Remarks		Note 1	Note 2	Note 2

Note 1: "-E" is HART 5 exclusive model and will be terminated. "-J" is recommended for HART communication.
 Note 2: HART protocol revision for the device and HART configuration tool
 HART 7 communication is supported by Field-Mate R2.04 or later.

	Protocol revision supported by HART configuration tool	
	5	7
AXR, HART 5	Available	Available
AXR, HART 7	Not available	Available

Indicator (*2):
 Full dot-matrix LCD (128 x 64 pixels)
 Operational switch: 4 magnet switches (including push switches)

Lightning Protector:
 When optional code A is selected, the lightning protector is built into the power supply and digital output terminals.

Protection:
 General-purpose Use/TIIS Flameproof type:
 IP66/IP67, Type 4X
 Explosion proof type except for TIIS:
 In the case of explosion proof type except TIIS, read description of "Enclosure" in "HAZARDOUS AREA CLASSIFICATION".

Converter Coating:
 Case and Cover: Corrosion-resistant coating
 Coating Color: Mint-green paint (Munsell 5.6 BG 3.3/2.9 or its equivalent)

Converter Material:
 Case and Cover: Aluminum alloy

Mounting/Shapes:

- Electrical Connection: ANSI 1/2 NPT female
 ISO M20 x 1.5 female
 JIS G1/2 female
- Direction of Electrical Connection: The direction can be changed even after delivery.
- Terminal Connection: M4 size screw terminal

Grounding:
 Grounding resistance of 100 Ω or less is necessary. When the optional code A is selected, grounding resistance of 10 Ω or less shall be required.
 * In case of TIIS explosion proof type, read description of HAZARDOUS AREA CLASSIFICATION.
 * For an explosion proof type except for TIIS, follow the domestic electrical requirements in each country.

Functions

How to Set Parameters (*2):
 Both of four push buttons and magnet switches can be used for setting. The magnet switches can be used to set parameters without opening the case cover.
 The magnet switches need operational magnets (optional code BM). These are also available as part number F9840PA.
 Users can choose a language on indicator from English, Japanese, German, French, Italian, and Spanish. Parameters can also be set with the configuration tool (Such as HHT (handheld terminal) or FieldMate, etc.). The language for the HHT is English only.

Instantaneous Flow Rate/Totalized Value Display Functions (for models with an indicator) (*2):

The full dot-matrix LCD enables user selections of displays from one line to three lines for:

- Instantaneous flow rate
- Instantaneous flow rate (%)
- Instantaneous flow rate (bar graph)
- Current output value (mA)
- Totalized forward-direction flow rate
- Totalized reverse-direction flow rate
- Totalized differential flow rate
- Tag No.
- Results of electrode adhesion diagnosis
- Communication type

Totalizer Display Function (*2):

The flow rate is counted one count at a time according to the setting of totalization pulse weights. For forward and reverse flow measurement functions, the totalized values of the flow direction (forward or reverse) and the flow direction are displayed on the indicator together with the units. The difference of totalized values between the forward and reverse flow rate can be displayed. Totalization for the reverse flow rate is carried out only when "Forward and reverse flow measurement functions" is selected.

Damping Time Constant (*2):

The time constant can be set from 1.0 second to 200.0 seconds (63% response). The default is 5 seconds.

When the damping time is short, the output fluctuates. Set the time to 5 seconds or more for control loop.

Span Setting Function (*2):

Span flows can be set in units such as volume flow rate, mass flow rate, time, or flow rate value. The velocity unit can also be set.

- Volume Flow Rate Unit: kcf, cf, mcf, Mgal (US), kgal (US), gal (US), mgal (US), kbbl (US)*, bbl (US)*, mbbl (US)*, μbbl (US)*, MI (megaliter), m³, kl (kiloliter), l (liter), cm³
 - Mass Flow Rate Unit (Density must be set): klb (US), lb (US), t (ton), kg, g
 - Velocity Unit: ft, m (meter)
 - Time Unit: s (sec), min, h (hour), d (day)
- * "US Oil" or "US Beer" can be selected.

Pulse Output (*1)(*2):

Scaled pulse is output one by one according to the setting of pulse weight.

Pulse Width: Duty 50% or fixed pulse width (0.05, 0.1, 0.5, 1, 20, 33, 50, 100, 200, 330, 500, 1000, 2000 ms) can be selected.

Output Rate: 0.0001 to 10,000 pps (pulses per second)

Multi-range Functions (*1)(*2):

Automatic range switching
 When the flow rate exceeds 100% of the range, transition to the next range (up to two ranges) is carried out automatically. Range switching can be confirmed by the status output and on the indicator.

Forward and Reverse Flow Measurement Functions (*1)(*2):

Flows in both forward and reverse directions can be measured. The reverse flow measurement can be confirmed by the status output and on the indicator.

Totalization Switch (*1)(*2):

The status output is carried out when a totalized value becomes equal to or greater than the set value.

Preset Totalization (*1)(*2):

The parameter setting enables a totalized value to be preset to a setting value or zero.

Alarm Selection Function (*2):

Alarms are classified into the System Alarms (hardware failure), Process Alarms (such as Signal Overflow and Adhesion Alarm), Setting Alarms, and Warnings. Process Alarms and Setting Alarms can be activated or deactivated for each item. The current output for an alarm can be selected from the following settings. If any System Alarm occurs, turn the power off and back on again to return to the normal condition.

- System Alarm: 21.6 mA or more, 3.2 mA or less
- Process Alarm, Setting Alarm: 21.6 mA or more, 20.5 mA, HOLD (fixed to the current value before the alarm), 4 mA, 3.8 mA, 3.2 mA or less

The default settings of each alarm are as follows:

	Standard	Optional code C1
System Alarm	21.6 mA or more	3.2 mA or less
Process Alarm (Note)		
Setting Alarm (Note)		

Note: In the case of style:S1 with optional code C1, the current output is set up to 3.8 mA during Process Alarms and Setting Alarms.

NE-107 Alarm Message (*2):

Alarms are classified into 4 categories by NAMUR NE-107 and can be displayed.

- F: Failure
- C: Function check
- S: Out of specification
- M: Maintenance required

Alarm Output (*1)(*2):

Alarms are generated only for the items selected via the 'Alarm Selection Function' if relevant failures occur.

Self Diagnosis Functions (*2):

When an alarm is output, details of the System Alarms, Process Alarms, Setting Alarms, and Warnings are displayed together with the specific description of corresponding countermeasures. Results of mean flow measurement during a given period, etc. can be checked by using parameters.

Flow Rate Upper/Lower Limit Alarms (*1)(*2):

If a flow rate becomes out of the predetermined range, the alarm output is generated.

Electrode Adhesion Diagnosis Function (*1) (*2):

This function enables checking of the adhesion level of insulating substances to the electrodes. Depending on the status of adhesion, users are notified by a warning or an alarm via status outputs. While adhesion diagnosis is being carried out (approximately 5 minutes), a current of 4 mA is output because the flow measurement is not performed. Adhesion diagnosis should only be carried out when the fluid velocity is completely zero by closing the valve. When adhesion diagnosis is carried out, change the control loop to the manual mode first.

Data Security during Power Failure:

Data (parameters, totalization value, etc.) storage by EEPROM. No back-up battery required.

Low Cut (*2):

In this function, the values of the current output along with LCD indication, totalization, and pulse, which are corresponding to setting span of 0 to 20%, are fixed at 0% (including reverse flow). The default setting is 3%. When the Low Cut point is small, the incorrect output may occur at the flow rate of zero. Set the Low Cut point to 3% or more. If the span is small, the damping time is short or the fluid is low conductivity, the incorrect output may easily occur at the flow rate of zero.

Zero Adjustment Function (*2):

By using the parameter setting, zero adjustment is carried out to ensure that the output for zero flow is 0%. Zero adjustment should be carried out only when the flowtube is filled with measurement fluid and the flow is completely stopped by closing the valves. During zero adjustment (450 seconds), the current output is 10.4 mA.

● **Flowtubes**

Size of AXR Flowtubes:

Lay length code 1 **Unit: mm (in.)**

Use	Process Connection	Integral Flowmeter
General-purpose Use/Explosion Proof Type	Wafer ^{*1}	80 (3.0), 100 (4.0), 150 (6.0), 200 (8.0)
	Flange ^{*1}	25 (1.0), 40 (1.5), 50 (2.0), 65 (2.5), 80 (3.0), 100 (4.0), 150 (6.0), 200 (8.0)

*1: The dimensions of lay length code 1 are the same as those of the PFA lining standard lay length (lay length code 1) in the AXF series. For details, read "EXTERNAL DIMENSIONS."

Lay length code 2 **Unit: mm (in.)**

Use	Process Connection	Integral Flowmeter
General-purpose Use/Explosion Proof Type	Wafer ^{*2}	25 (1.0), 40 (1.5), 50 (2.0), 65 (2.5), 80 (3.0), 100 (4.0), 150 (6.0), 200 (8.0)

*2: Excluding the size of 65 mm, dimensions of lay length code 2 are the same as those of PFA lining replacement models (lay length code 2) in AXF series. Lay lengths for special gaskets (optional codes GA, GC, GD) are different. For details, read "EXTERNAL DIMENSIONS."

Coating:

General-purpose Use/Explosion Proof Type:

- Size 25 to 100 mm (1 to 4 in.) (Wafer type),
- Size 25 to 100 mm (1 to 4 in.) (Flange type):
 - Housing: No coating (Stainless steel surface)
 - Flange (Flange type only):
 - No coating (Stainless steel surface)
- Size 150 to 200 mm (6.0 to 8 in.) (Wafer type),
- Size 150 to 200 mm (6.0 to 8 in.) (Flange type):
 - Housing, Flange (Flange type only)
 - Corrosion-resistant coating
 - Coating color; Mint green (Munsell 5.6 BG 3.3/2.9 or its equivalent)

Flowtube Material:

Size 25 to 100 mm (1 to 4 in.)

Part Name		Material	
Housing		Stainless steel-JIS SUS304 (AISI 304 SS/EN 1.4301 equivalent)	
Flange		Stainless steel-JIS SUS304 or SUSF304 (AISI 304 SS/EN 1.4301 equivalent)	
Mini-Flange	Wafer type	Size 25 mm (1.0 in.)	Stainless steel-SCS13
		Size 40 to 100 mm (1.5 to 4.0 in.)	Stainless steel-JIS SUS430 ASTM 4300/DIN X6Cr17/ EN 1.4016 equivalent
Pipe	Wafer type	Size 25 mm (1.0 in.)	Stainless steel-SCS13
		Size 40 to 100 mm (1.5 to 4.0 in.)	Stainless steel-JIS SUS304 (AISI 304 SS/EN 1.4301 equivalent)
	Flange type	Size 25 mm (1.0 in.)	Stainless steel-SCS13
		Size 40 to 100 mm (1.5 to 4.0 in.)	Stainless steel-JIS SUS304 (AISI 304 SS/EN 1.4301 equivalent)

Size 150 mm (6.0 in.) to 200 mm (8.0 in.)

Part Name		Material
Housing		Carbon steel-JIS SPCC equivalent
Flange	Process Connection code: B**	Stainless steel-JIS SUS304 or SUSF304 (AISI 304 SS/EN 1.4301 equivalent)
	Process Connection code: C**	Carbon steel-JIS SS400 or SFVC 2A
Mini-Flange	Wafer Type	Carbon steel-JIS SS400 or SFVC 2A
Pipe	Flange Type/Wafer Type	Stainless steel-JIS SUS 304 (AISI 304 SS/EN 1.4301 equivalent)

Wetted Part Material:

Lining;

Fluorocarbon PFA^{*1} lining

*1: PFA is FDA (U.S. Food and Drug Administration) approval material. The inner surface of the PFA lining is mirror-finished to Ra of 0.05 to 0.15 μm. The value of Ra is the average of measurements at several points. Mirror finished PFA lining is standard for size 25 to 100 mm (1 to 4 in.) and optional for size 150 to 200 mm (6 to 8 in.) specified by optional code PM.

Electrode;

Stainless steel-JIS SUS316L (AISI 316L SS/EN 1.4404 equivalent), HASTELLOY^{*1} C-276 equivalent, Tantalum, Platinum-Iridium

Grounding Ring/Grounding Electrode;

- Grounding Ring (plate type)
Stainless steel-JIS SUS316 (AISI 316 SS/EN 1.4401 equivalent), Stainless steel-JIS SUS316L or ASTM 316L (AISI 316L SS/EN 1.4404 equivalent), HASTELLOY™ C-276 equivalent
- Grounding Electrode (electrode type)²
Fluorocarbon PFA lining + grounding electrode (Tantalum, Platinum-Iridium)

*1: Hastelloy is a registered trademark of Haynes International Inc.

*2: The permeable fluids (such as nitric acid, hydrofluoric acid, or sodium hydroxide at high temperature) are unusable.

Gasket;

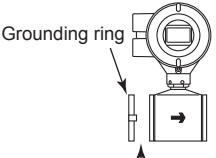
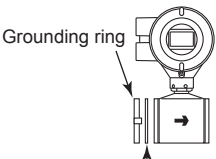
Use	General-purpose Use/ Explosion Proof Type
Standard	 <p>No gasket within Flowtube</p>
Optional code (GA, GC, or GD)	 <p>Gasket within Flowtube</p>
	Gasket Material (within Flowtube)
	GA: Fluororubber for PVC pipes (Viton) GC: Acid-resistant fluororubber for PVC pipes (Viton) GD: Alkali-resistant fluororubber for PVC pipes (Viton)

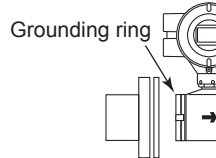
Use	General-purpose Use/ Explosion Proof Type
Optional code (BSF or BSC)	 <p>Flange of user's pipe Gasket for user's flange</p>
	Gasket Material (for user's flange)
	BSF: PTFE-sheathed non-asbestos BSC: Chloroprene rubber

Recommended Gaskets Between Flowtubes And User's Flanges:

Gaskets Type

Use compressed non-asbestos fiber gaskets, PTFE-sheathed non-asbestos gaskets or gaskets which have equivalent elasticity.
For optional codes GA, GC, and GD, use rubber gaskets or others which have equivalent elasticity.

Gaskets Size

Be sure to choose a gasket with an inner and outer diameter that does not protrude inside the piping (Read item of Inner Diameter Of Grounding Ring, Outer Diameter For Effective Sealing).

If the inner diameter of the gasket is too large, or outer diameter of the gasket is too small, fluid leakage may result.

Inner Diameter of Grounding Ring, Outer Diameter for Effective Sealing, Recommended Inner Diameter of Gasket;

Lay length code 1;

Unit: mm (in.)

Size	PFA lining			
	Wafer, Flange			
	Inner Diameter of Grounding Ring [øA]	Outer Diameter for Effective Sealing [øB]	Recommended Inner Diameter of Gasket	
Flat Gasket [øC]			PTFE-sheathed Non-asbestos Gasket [øD]	
25 (1.0)	28 (1.10)	53 (2.09)	35 (1.38)	
40 (1.5)	41 (1.61)	71 (2.80)	49 (1.93)	
50 (2.0)	53 (2.09)	84 (3.31)	61 (2.40)	
65 (2.5)	66 (2.60)	103 (4.06)	84 (3.31)	
80 (3.0)	77 (3.03)	114 (4.49)	90 (3.54)	
100 (4.0)	102 (4.02)	140 (5.51)	115 (4.53)	
150 (6.0)	146.1 (5.75)	190 (7.48)	167 (6.57)	
200 (8.0)	193.6 (7.62)	240 (9.45)	218 (8.58)	

Lay length code 2;

Unit: mm (in.)

Size	PFA lining			
	Wafer			
	Inner Diameter of Grounding Ring [øA]	Outer Diameter for Effective Sealing [øB]	Recommended Inner Diameter of Gasket	
Flat Gasket [øC]			PTFE-sheathed Non-asbestos Gasket [øD]	
25 (1.0)	28 (1.10)	53 (2.09)	35 (1.38)	
40 (1.5)	41 (1.61)	71 (2.80)	49 (1.93)	
50 (2.0)	53 (2.09)	84 (3.31)	61 (2.40)	
65 (2.5)	66 (2.60)	103 (4.06)	84 (3.31)	
80 (3.0)	77 (3.03)	114 (4.49)	90 (3.54)	
100 (4.0)	102 (4.02)	140 (5.51)	115 (4.53)	
150 (6.0)	140.7 (5.54)	190 (7.48)	167 (6.57)	
200 (8.0)	188.9 (7.44)	240 (9.45)	218 (8.58)	

Size of Inner Diameter of Grounding Ring, Outer Diameter for Effective Sealing and Recommended Inner Diameter of Gasket:

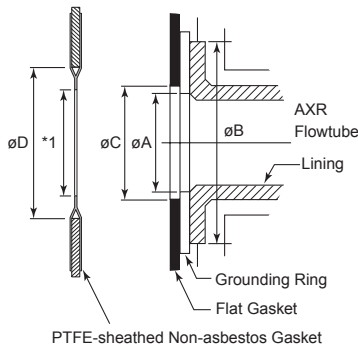

*1: Do not have this length be smaller than the inner diameter of grounding ring (øA). F06.ai

Electrode Construction:
Internal insertion type

HAZARDOUS AREA CLASSIFICATION

When selecting the explosion protection type, specify the appropriate suffix code that has the explosion protection certification approved by the certification body of each country to be used.

ATEX:

Applicable Standard:
EN 60079-0, EN 60079-1,
EN 60079-7, EN 60079-11,
EN 60079-31
Certificate: DEKRA 11ATEX0144

Type of Gas Atmosphere Protection

Type of Protection:
Group: II
Category: 2G
Ex db e ia IIC T6...T4 Gb
Specification of Protection:
Electrode Circuit: Um=250 V
Power Supply/Current Output:
42 Vdc max., 4 to 20 mA, Um=250 V
Digital Output: ON; 2 Vdc, 120 mA max.
OFF; 30 Vdc max., 4 mA, Um=250 V
Excitation Circuit: 29 V max.
Enclosure: IP66/IP67
Process Temperature:

Temperature Class	Maximum Process Temperature	Minimum Process Temperature
T6	+70°C (+158°F)	-30°C (-22°F)
T5	+85°C (+185°F)	-30°C (-22°F)
T4	+130°C (+266°F)	-30°C (-22°F)

Ambient Temp.: -30°C to +55°C
(-22°F to +131°F)

Type of Dust Atmosphere Protection

Type of Protection:
Group: II
Category: 2D
Ex tb IIIC T90°C, T110°C, T130°C Db
Specification of Protection:
Electrode Circuit: Um=250 V
Power Supply/Current Output:
42 Vdc max., 4 to 20 mA, Um=250 V

Digital Output: ON; 2 Vdc, 120 mA max.
OFF; 30 Vdc max., 4 mA, Um=250 V
Excitation Circuit: 29 V max.
Enclosure: IP66/IP67
Process Temperature:

Maximum Surface Temperature	Maximum Process Temperature	Minimum Process Temperature
T90°C (+194°F)	+70°C (+158°F)	-30°C (-22°F)
T110°C (+230°F)	+85°C (+185°F)	-30°C (-22°F)
T130°C (+266°F)	+130°C (+266°F)	-30°C (-22°F)

Ambient Temp.: -30°C to +55°C
(-22°F to +131°F)

Note: Grounding resistance of 100Ω or less is necessary.
When the optional code A is selected, grounding resistance of 10Ω or less shall be required.

FM

Applicable Standard:
FM3600, FM3610, FM3615,
FM3810, ANSI/NEMA250

Type of Protection:

Explosionproof for Class I, Division 1, Groups A, B, C & D
Dust-ignitionproof for Class II/III, Division 1, Groups E, F & G
With intrinsically safe electrodes for Class I, Division 1, Groups A, B, C & D
"SEAL ALL CONDUITS WITHIN 18 INCHES"
WHEN INSTALLED IN DIV. 2, "SEALS NOT REQUIRED"

Specification of Protection:

Electrode Circuit Um: 250 V
Power Supply/Current Output:
42 Vdc max. / 4 to 20 mA
Digital Output: ON; 2 Vdc, 120 mA max.
OFF; 30 Vdc max., 4 mA
Excitation Circuit: 29 V max.
Enclosure: NEMA Type 4X
Process Temperature:

Temperature Code	Maximum Process Temperature	Minimum Process Temperature
T6	+70°C (+158°F)	-40°C (-40°F)
T5	+85°C (+185°F)	-40°C (-40°F)
T4	+130°C (+266°F)	-40°C (-40°F)

Ambient Temp.: -40°C to +55°C
(-40°F to +131°F)

Note: Installation shall be in accordance with the manufacturer's instructions, National Electric Code, ANSI/NFPA-70, and Local Electric Code.

CSA

Certificate No.: 2136807

For Division system of area classification

Applicable Standard:
C22.2 No.0, C22.2 No.0.4, C22.2 No.0.5,
C22.2 No.25, C22.2 No.30, C22.2 No.94,
C22.2 No.157, C22.2 No.61010-1

Type of Protection:

Class I, Groups A, B, C and D;
Class II, Groups E, F and G; Class III
With Intrinsically Safe Electrodes for Class I,
Groups A, B, C and D

Specification of Protection :

Electrode Circuit Um: 250 V
Power Supply/Current Output: 42Vdc max./
4 to 20mA

Digital Output:
 On: 2Vdc, 120mA max.
 Off: 30Vdc max., 4mA
 Excitation Circuit: 29V max.
 Enclosure: Type 4X
 Process Temperature:

Temperature Code	Maximum Process Temperature	Minimum Process Temperature
T6	+70°C (+158°F)	-40°C (-40°F)
T5	+85°C (+185°F)	-40°C (-40°F)
T4	+130°C (+266°F)	-40°C (-40°F)

Ambient Temperature: -40 to +55°C (-40°F to +131°F)

For Zone system of area classification

Applicable Standard:
 C22.2 No.60079-0, E60079-1, E60079-7,
 E60079-11, E61241-1-1, C22.2 No.61010-1

Type of Gas Atmosphere Protection

Type of Protection:
 Ex d e [ia] IIC T6...T4
 with Intrinsically Safe Electrodes for Zone 0,
 Ex ia IIC T6...T4

Specification of Protection:
 Electrode Circuit Um: 250 V
 Power Supply/Current Output: 42Vdc max./
 4 to 20mA

Digital Output:
 On: 2Vdc, 120mA max.
 Off: 30Vdc max., 4mA
 Excitation Circuit: 29V max.
 Enclosure: IP66/IP67
 Process Temperature:

Temperature Code	Maximum Process Temperature	Minimum Process Temperature
T6	+70°C (+158°F)	-40°C (-40°F)
T5	+85°C (+185°F)	-40°C (-40°F)
T4	+130°C (+266°F)	-40°C (-40°F)

Ambient Temperature: -40 to +55°C (-40°F to +131°F)

Type of Dust Atmosphere Protection

Type of Protection:
 DIP A21 T_A 90°C, 110°C, 130°C
 Specification of Protection:
 Electrode Circuit Um: 250 V
 Power Supply/Current Output: 42Vdc max./
 4 to 20mA

Digital Output:
 On: 2Vdc, 120mA max.
 Off: 30Vdc max., 4mA
 Excitation Circuit: 29V max.
 Enclosure: IP66/IP67
 Process Temperature:

Maximum Surface Temperature T _A	Maximum Process Temperature	Minimum Process Temperature
90°C	+70°C (+158°F)	-40°C (-40°F)
110°C	+85°C (+185°F)	-40°C (-40°F)
130°C	+130°C (+266°F)	-40°C (-40°F)

Ambient Temperature: -40 to +55°C (-40°F to +131°F)

Process Sealing Certification:

Dual Seal certified by CSA to the requirements of ANSI/ISA 12.27.01.
 No additional sealing required.
 Primary seal failure annunciation;
 Deterioration of the flowrate output at nonzero flow point.
 Unstable flowrate output at zero flow point.

○ IECEx:

Applicable Standard:
 IEC60079-0, IEC60079-1,
 IEC60079-7, IEC60079-11,
 IEC60079-31
 Certificate: IECEx DEK 11.0053

Type of Gas Atmosphere Protection

Type of Protection:
 Ex db e ia IIC T6...T4 Gb
 Specification of Protection:
 Electrode Circuit: Um=250 V
 Power Supply/Current Output:
 42 Vdc max., 4 to 20 mA, Um=250 V
 Digital Output: ON; 2 Vdc, 120 mA max.
 OFF; 30 Vdc max., 4 mA, Um=250 V
 Excitation Circuit: 29 V max.
 Enclosure: IP66/IP67
 Process Temperature:

Temperature Class	Maximum Process Temperature	Minimum Process Temperature
T6	+70°C (+158°F)	-30°C (-22°F)
T5	+85°C (+185°F)	-30°C (-22°F)
T4	+130°C (+266°F)	-30°C (-22°F)

Ambient Temp.: -30°C to +55°C (-22°F to +131°F)

Type of Dust Atmosphere Protection

Type of Protection:
 Ex tb IIIC T90°C, T110°C, T130°C Db
 Specification of Protection:
 Electrode Circuit: Um=250 V
 Power Supply/Current Output:
 42 Vdc max., 4 to 20 mA, Um=250 V
 Digital Output: ON; 2 Vdc, 120 mA max.
 OFF; 30 Vdc max., 4 mA, Um=250 V
 Excitation Circuit: 29 V max.
 Enclosure: IP66/IP67
 Process Temperature:

Maximum Surface Temperature	Maximum Process Temperature	Minimum Process Temperature
T90°C (+194°F)	+70°C (+158°F)	-30°C (-22°F)
T110°C (+230°F)	+85°C (+185°F)	-30°C (-22°F)
T130°C (+266°F)	+130°C (+266°F)	-30°C (-22°F)

Ambient Temp.: -30°C to +55°C (-22°F to +131°F)

Note: Grounding resistance of 100Ω or less is necessary.
 When the optional code A is selected, grounding resistance of 10 Ω or less shall be required.

○ TIIS

Certificate:

Size: mm(inch)	Wafer Type -A**	Flange Type -B**
25 (1.0)	TC19746	TC19746
40 (1.5)	TC19747	TC19747
50 (2.0)	TC19748	TC19748
65 (2.5)	TC19749	TC19749
80 (3.0)	TC19750	TC19750
100 (4.0)	TC19751	TC19751
150 (6.0)	TC19753	TC19754
200 (8.0)	TC19756	TC19757

Construction: Ex d e [ia] IIC T4

Converter: Flameproof enclosure and intrinsically safety (ia)

Flowtube: Increased safety and intrinsically safety (ia)

Electrode: Intrinsically safety (ia)

Gas Group And Temperature Class: IIC T4

- Non-intrinsically safety circuit
 - Supply Voltage: 14.7 to 42 V dc
 - Output Signal: 4 to 20 mA dc
 - Digital output: ON; 2 V dc, 120 mA, OFF; 30 V dc, 4 mA
 - Allowable Voltage (Um): 250 V ac 50/60Hz, 250 V dc
 - Excitation Circuit: 29 V
- Intrinsically safety circuit
 - Maximum Voltage (Uo): 14 V
 - Maximum Current (Io): 17 mA
 - Maximum Electrical Power (Po): 0.12 W
- Fluid Temperature: -20 to 130°C
- Ambient Temperature: -20 to 55°C
- Grounding:
 - Grounding resistance of 10 Ω or less is necessary for class A grounding terminal.
 - Grounding resistance of 100 Ω or less is necessary for Functional grounding terminal.
 - When the optional code A is selected, grounding resistance of 10 Ω or less shall be required.
- Flameproof packing adapter:
 - The specifying optional code G11 is necessary.
 - In case of two flameproof packing adapters, specify optional code G32 with G11.

■ STANDARD PERFORMANCE

Accuracy:

General-Purpose Use; Vs: Span setting value (m/s)

Size in mm (in.)	Span in m/s (ft/s)	Accuracy
25 to 100 (1 to 4)	0.3 ≤ Vs < 1 (1 ≤ Vs < 3.3)	±0.25 cm/s (at indications less than 50% of span)
		±(0.4+0.1/Vs)% of rate (at indications 50% or more of span)
	1 ≤ Vs < 2 (3.3 ≤ Vs < 6.7)	±0.2% of span (at indications less than 35% of span)
±0.5% of rate (at indications 35% or more of span)		
150 to 200 (6 to 8)	0.3 ≤ Vs < 1 (1 ≤ Vs < 3.3)	±0.16% of span (at indications less than 30% of span)
		±0.5% of rate (at indications 30% or more of span)
	1 ≤ Vs < 2 (3.3 ≤ Vs < 6.7)	±0.3% of span (at indications less than 35% of span)
±0.5% of rate (at indications 35% or more of span)		
2 ≤ Vs ≤ 10 (6.7 ≤ Vs ≤ 33)	±0.16% of span (at indications less than 30% of span)	
	±0.5% of rate (at indications 30% or more of span)	

Explosion proof Type; Vs: Span setting value (m/s)

Size in mm (in.)	Span in m/s (ft/s)	Accuracy
25 to 100 (1 to 4)	$0.3 \leq V_s < 1$ ($1 \leq V_s < 3.3$)	± 0.30 cm/s (at indications less than 50% of span)
		$\pm(0.3+0.2/V_s)\%$ of rate (at indications 50% or more of span)
	$1 \leq V_s < 2$ ($3.3 \leq V_s < 6.7$)	$\pm 0.3\%$ of span (at indications less than 35% of span)
		$\pm 0.5\%$ of rate (at indications 35% or more of span)
	$2 \leq V_s \leq 10$ ($6.7 \leq V_s \leq 33$)	$\pm 0.16\%$ of span (at indications less than 30% of span)
		$\pm 0.5\%$ of rate (at indications 30% or more of span)
150 to 200 (6 to 8)	$0.3 \leq V_s < 1$ ($1 \leq V_s < 3.3$)	± 0.50 cm/s (at indications less than 50% of span)
		$\pm(0.5/V_s)\%$ of rate (at indications 50% or more of span)
	$1 \leq V_s < 2$ ($3.3 \leq V_s < 6.7$)	$\pm 0.45\%$ of span (at indications less than 30% of span)
		$\pm 0.25\%$ of span (at indications from 30% or more to less than 45% of span)
		0.5% of rate (at indications 45% or more of span)
	$2 \leq V_s \leq 10$ ($6.7 \leq V_s \leq 33$)	$\pm 0.24\%$ of span (at indications less than 35% of span)
		$\pm 0.5\%$ of rate (at indications 35% or more of span)

The accuracy of a product before shipment is defined as totalized value at the result of calibration test in our water actual flow test facility.

Calibrated conditions in our water actual test facility are as follows:

- Fluid temperature: $20 \pm 10^\circ\text{C}$
- Ambient temperature: $20 \pm 5^\circ\text{C}$
- Length of straight runs: 10 D or more on the upstream side; 5 D or more on the downstream side
- Reference conditions: Similar to BS EN29104 (1993); ISO 9104 (1991)

Accuracy for Multi-drop of HART (generally accepted values)

Vs: Span setting value (m/s)

Size in mm (in.)	Span in m/s (ft/s)	Accuracy
25 to 200 (1 to 8)	$0.3 \leq V_s < 1$ ($1 \leq V_s < 3.3$)	$\pm(0.4+0.3/V_s)\%$ of span
	$1 \leq V_s < 2$ ($3.3 \leq V_s < 6.7$)	$\pm 0.5\%$ of span
	$2 \leq V_s \leq 10$ ($6.7 \leq V_s \leq 33$)	$\pm 0.25\%$ of span (at indications less than 50% of span)
$\pm 0.5\%$ of rate (at indications 50% or more of span)		

Repeatability (Reference):

$\pm 0.2\%$ of rate
(When the flow velocity is 1.5 m/s toward 2 m/s of setting span)

Insulation Resistance:

Inspection location	Terminal	Test voltage	Standard
Power Supply/Digital Output - Functional Grounding	SUPPLY/DO \perp	500 V DC	100 M Ω or more

When the optional code A is selected (with the lightning protector), values are as follows.

Power Supply/Digital Output - Functional Grounding	SUPPLY/DO \perp	100 V DC	20 M Ω or more
--	----------------------	----------	-----------------------

Note: Conduct the test according to the instruction manual.

Dielectric Strength:

Inspection location	Terminal	Test voltage	Test time	Standard
Power Supply/Digital Output - Functional Grounding	SUPPLY/DO \perp	500 V AC	1 min.	25 mA or less

When the optional code A is selected (with the lightning protector), values are as follows.

Power Supply/Digital Output - Functional Grounding	SUPPLY/DO \perp	100 V AC	1 min.	6 mA or less
--	----------------------	----------	--------	--------------

Note: Conduct the test according to the instruction manual.

CE Marking:

CE marking is affixed on the name plate except for models with any of the following specifications.
 • Optional Code: FF1, CF1, SF2, JF3

Safety Requirement Standards:

CAN/CSA C22.2 No.61010-1-04
 • Altitude of installation site: Max. 2000 m above sea level
 • Installation category: I
 "Overvoltage category (Installation category)" describes a number which defines a transient overvoltage condition. It implies the regulation for impulse withstand voltage. "I" applies to electrical equipment which is supplied from the circuit when appropriate transient overvoltage control means (interfaces) are provided.

- Pollution degree: 2
“Pollution degree” describes the degree to which a solid, liquid, or gas which deteriorates dielectric strength or surface resistivity is adhering. “2” applies to normal indoor atmosphere. Normally, only non-conductive pollution occurs. Occasionally, however, temporary conductivity caused by condensation must be expected.
- Indoor/Outdoor use

EMC Conformity Standards:

EN61326-1 Class A, Table 2 (For use in industrial locations)
EN61326-2-3

Pressure Equipment Directive:

Module: H
Type of Equipment: Piping
Type of Fluid: Liquid and Gas
Group of Fluid: 1 and 2 (*4)

General-purpose Use/Explosion Proof Type;

MODEL	DN (mm) (*1)	PS (MPa) (*1)	PS · DN (MPa · mm)	CATEGORY (*2) (*4)
AXR025G	25	4	100	Sound Engineering Practice (SEP) (*3)
AXR025C				
AXR040G	40	4	160	II
AXR040C				
AXR050G	50	4	200	II
AXR050C				
AXR065G	65	2	130	II
AXR065C				
AXR080G	80	2	160	II
AXR080C				
AXR100G	100	2	200	II
AXR100C				
AXR150G	150	2	300	II
AXR150C				
AXR200G	200	2	400	III
AXR200C				

*1: PS: Maximum allowable pressure for Flowtube
DN: Nominal size
*2: For details, refer to the following.
Table 6 covered by ANNEX II of Directive 97/23/EC (until July 18th, 2016)
Table 6 covered by ANNEX II of Directive 2014/68/EU (from July 19th, 2016)
*3: Article 3, paragraph 3 of Directive 97/23/EC (until July 18th, 2016)
Article 4, paragraph 3 of Directive 2014/68/EU (from July 19th, 2016)
*4: Models classified in CATEGORY II shall not be used for unstable gases of Group 1.

SIL Certification:

AXR series are certified by exida in compliance with the following standards;
IEC 61508: 2010; Part1 to Part7
Functional Safety of Electrical/electronic/programmable electronic safety-related systems; SIL 2 capability for single flowmeter use, SIL 3 capability for dual flowmeter use.

■ NORMAL OPERATING CONDITIONS

Ambient Temperature:

General-purpose USE:
–40 to +55°C (–40 to +131°F)
Explosion proof type:

In the case of explosion proof type, read description of “Enclosure” or “Ambient Temperature” in “HAZARDOUS AREA CLASSIFICATION”

*1: Minimum temperature should also be limited according to minimum fluid temperature of flow tube’s specification. Read description of “Fluid Temperature and Pressure”.
*2: Indicator operating range: –20 to +55°C (–4 to +131°F)

Ambient Humidity: 0 to 100%

Lengthy continuous operation at 95% or more is not recommended.

Fluid Conductivity:

Size 25 to 200 mm (1 to 8 in.): 10 μS/cm or larger
Note: Fluids with large flow noise (pure water, fluids with low conductivity and low viscosity such as alcohol) cause the output fluctuation and therefore it is impossible to measure accurately.

Output Fluctuation:

The output fluctuates depending on the fluid conditions and damping settings.
The following table shows the output fluctuation as a rough guideline at flow velocity near 100% of flow span (damping: 5 s)
• Size 25 to 100 mm (1 to 4 in.)

Fluid Conductivity [μS/cm]	Fluctuation (% of rate) as a rough guideline	
	Flow Span 2.0 m/s	Flow Span 4.0 m/s
10	3.0% or less	7.0% or less
50	1.0% or less	1.0% or less
100	0.5% or less	0.5% or less
500	0.5% or less	0.5% or less

• Size 150 to 200 mm (6 to 8 in.)

Fluid Conductivity [μS/cm]	Fluctuation (% of rate) as a rough guideline	
	Flow Span 2.0 m/s	Flow Span 4.0 m/s
10	5.0% or less	Non-recommendation
50	2.0% or less	3.0% or less
100	1.0% or less	1.0% or less
500	0.6% or less	1.0% or less

Measurable Flow Rate Range:

SI Units (Size: mm, Flow rate: m³/h)

Size (mm)	0 to Min. Span Flow Rate (0.3 m/s)	0 to Max. Span Flow Rate (10 m/s)
25	0 to 0.5302 m³/h	0 to 17.671 m³/h
40	0 to 1.3572	0 to 45.23
50	0 to 2.1206	0 to 70.68
65	0 to 3.584	0 to 119.45
80	0 to 5.429	0 to 180.95
100	0 to 8.483	0 to 282.74
150	0 to 19.090	0 to 636.1
200	0 to 33.930	0 to 1,130.9

English Units (Size: in., Flow rate: GPM)

Size (in.)	0 to Min. Span Flow Rate (1 ft/s)	0 to Max. Span Flow Rate (33 ft/s)
1.0	0 to 2.335 GPM	0 to 77.80 GPM
1.5	0 to 5.253	0 to 175.0
2.0	0 to 9.337	0 to 311.2
2.5	0 to 14.59	0 to 486.2
3.0	0 to 21.01	0 to 700.2
4.0	0 to 37.35	0 to 1244
6.0	0 to 84.03	0 to 2800
8.0	0 to 149.4	0 to 4979

Fluid Temperature and Pressure:

The following figure shows maximum allowable fluid pressure for the flowtube. Further fluid pressure should also be limited according to flange rating.

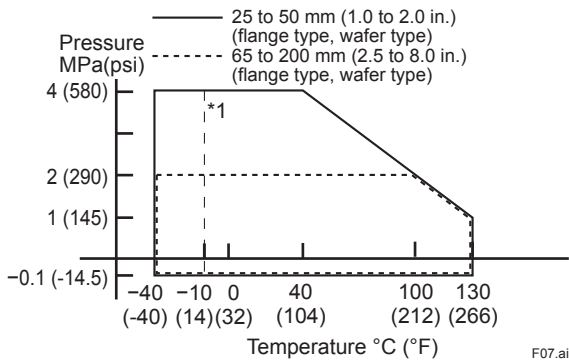

- *1: For wafer types of 40 to 200 mm (1.5 to 8.0 in.), and for carbon steel flange types (process connection code: C**) of 150 to 200 mm (6.0 to 8.0 in.), the minimum fluid temperature is -10°C ($+14^{\circ}\text{F}$).
- *2: For fluid temperature of the explosion proof type, read descriptions of "HAZARDOUS AREA CLASSIFICATION".

Vibration Conditions:

9.8 m/s² or less (frequency of 500 Hz or less)

- Note: Level of vibration is in conformity with IEC 60068-2-6 (SAMA 31.1-1980).
- Avoid locations with much vibration where the pipe vibration frequency is 500 Hz or more. Such a condition may cause damage to the instrument.

CAUTIONS FOR INSTALLATION

Mounting of Flowmeters and Required Length of Straight Runs

Based on JIS B 7554 and our piping condition test data, we recommend the piping conditions as shown in the following figures. This is not always enough when the piping line incorporates multiple conditions at the same time.

When installing two or more magnetic flowmeters on a single pipe, provide a run of at least 5D between them.

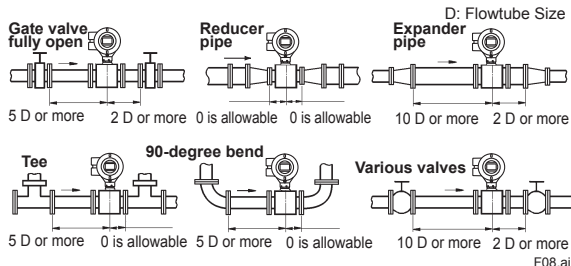

Required length of straight runs

- *1: Do not install anything in the flowmeter that may interfere with the magnetic field, electromagnetic force, or flow velocity distribution.
- *2: A straight run may not be required on the downstream side of the flowmeter. However, if a downstream valve or other fitting causes irregularity or deviation in flows, provide a straight run of 2D to 3D on the downstream side.
- *3: The valves shall be mounted on the downstream side so that deviated flows do not occur in the flowtube and to avoid startup from an empty condition.
- *4: In case the piping conditions are compounded, install on the straight pipe section where the upstream part is sufficiently rectified.

Maintaining Stable Fluid Conductivity

Do not install the flowmeter at a place where fluid conductivity tends to become uneven. If chemicals are fed on the upstream side of a magnetic flowmeter, they may affect the flow-rate's indications. To avoid this situation, it is recommended that the chemical feed ports be located on the downstream side of the flowmeter. If it is unavoidable that chemicals must be fed on the upstream side, provide a sufficient length of straight run (approximately 50D or more) to ensure the proper mixture of fluids.

Mounting Position

- Pipes must be fully filled with liquids.** If the pipe is empty, the output fluctuates or the Process Alarm (Signal Overflow) occurs. The pipe must be fully filled with liquid. Piping shall be designed so as to maintain the flowtube filled with fluids. Vertical mounting is effective in such cases as when fluids tend to separate or solid matter may be precipitated. When employing vertical mounting, direct the fluids from the bottom to the top to ensure that the pipes remain fully filled.

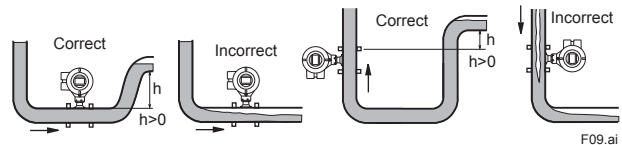

Mounting Positions

- Avoiding air bubbles.** If air bubbles enter a measurement pipe, the flow rate indication may be affected and measurement errors may occur. If the fluid contains air bubbles, arrange piping to prevent the bubbles from accumulating in a flowtube. Some operations of the valve may cause low pressure and create air bubbles in the pipes, so mount the flowtube on the upstream side of the valve to avoid possible low pressure and air bubbles.

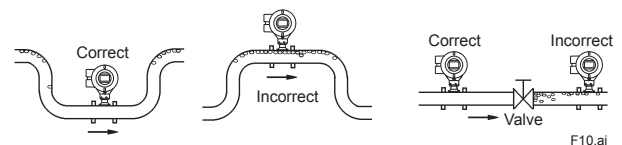

Avoiding Air Bubbles

• Mounting Orientation

Install the magnetic flowmeter so that the electrodes position is not perpendicular to the ground. Otherwise it may cause the measuring errors because air bubbles at upper side or slurry at downside covers the electrode.

Mount the transmitter of an integral flowmeter above the piping to prevent water from entering them.

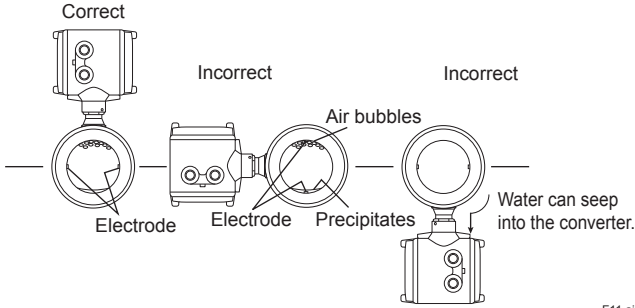

Mounting Orientation

Location

- The flowmeter should be installed away from electrical motors, transformers, inverters, and other power sources in order to avoid interference with measurement.
- Install the flowmeter in a location where it is not exposed to direct sunlight.

Grounding

For accurate measurement of flow rate, a reference electric potential needs to be kept in the magnetic flowmeter. Therefore, the magnetic flowmeter should be grounded in accordance with certain specifications (grounding resistance of 100 Ω or less, or 10 Ω or less depending on the selected explosion proof type and option). Grounding is mandatory especially for insulated piping such as PVC-sheathed pipes. If not, the magnetic flowmeter measures the flow incorrectly because the reference electrical potential is floating. Moreover, grounding is also mandatory in the simultaneous outputs of current and pulse. If not, the flowmeter causes a large measurement error because the outputs interfere with each other.

Applications

- For a fluid containing high concentration slurries or hard solids (such as earth and sand, metal powder, and fiber), contact of the solids on the electrode surface will make the output fluctuate. Therefore, two-wire magnetic flowmeters are not suitable for measuring such fluids. It is recommended to use the AXF four-wire magnetic flowmeter.
- In the vicinity of an electrolysis bath, strong stray current may flow in the fluid. It is recommended to use the AXF four-wire magnetic flowmeter in such an application.

■ ACCESSORIES

Centering device (wafer type only): 1 pc.
Plug: 1 pc.

■ TERMINAL CONFIGURATION AND TERMINAL WIRING

General-purpose Use/Explosion Proof Type except TIIS:

Terminal configuration Terminal wiring

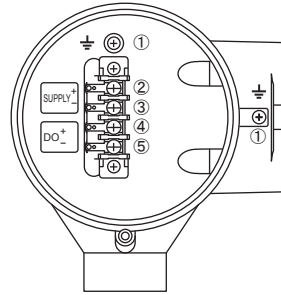

No.	Terminal Symbols	Description
①	⏏	Functional grounding
②	SUPPLY+	Power supply and current output
③	SUPPLY+	
④	DO+	Digital output (One output can be selected from pulse, alarm or status outputs.)
⑤	DO+	

F12.ai

TIIS Explosion Proof Type:

Terminal configuration Terminal wiring

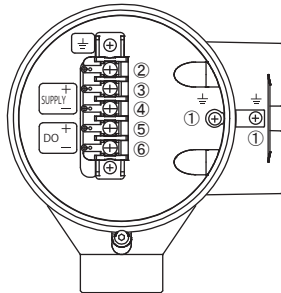

No.	Terminal Symbols	Description
①	⏏	Functional grounding
②	⏏	Class A grounding
③	SUPPLY+	Power supply and current output
④	SUPPLY+	
⑤	DO+	Digital output (One output can be selected from pulse, alarm or status outputs.)
⑥	DO+	

F12_02.ai

Recommended Power and Output Cable:

Use polyvinyl chloride insulated and sheathed portable power cables (JIS C3312) or equivalents.

Outer Diameter:

- With no gland option; 6.5 to 12 mm (0.26 to 0.47 in.)
- With gland options EG and EU; 10.5 or 11.5 mm (0.41 or 0.45 in.)
- With gland options EP; 6 to 12 mm (0.24 to 0.47 in.)

Nominal Cross Section:

- Single wire: 0.5 to 2.5 mm²
- Stranded wire: 0.5 to 1.5 mm²

■ WIRING EXAMPLE (General-purpose Use/Explosion Proof Type except TIIS)

● Current Output, Pulse Output, Status Output and Alarm Output (General-purpose Use/Explosion Proof Type except TIIS)

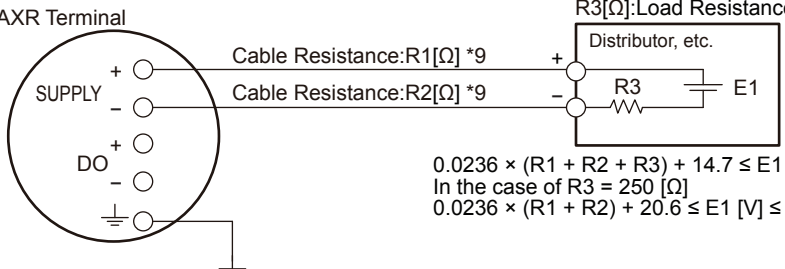
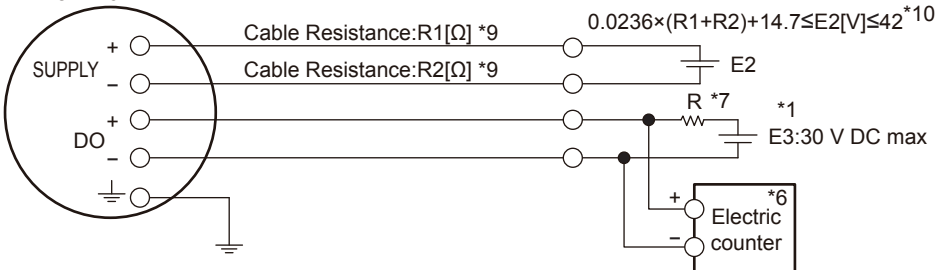
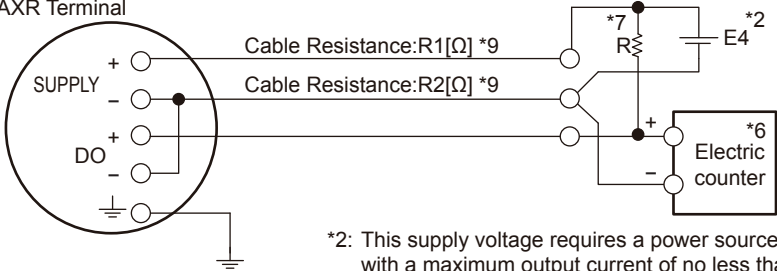
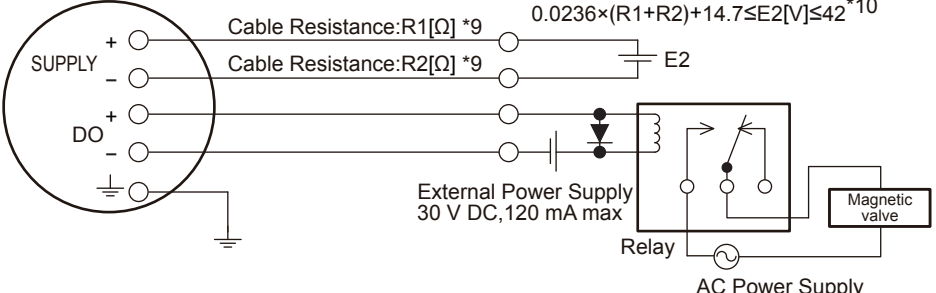
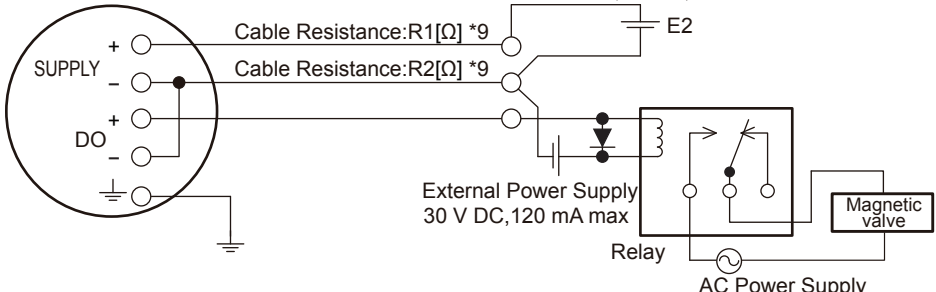
Connection	Description
<p>Current Output In this case, Communication is possible (up to a distance of 2 km when a CEV cable is used.)</p>	<p>AXR Terminal</p>  <p>Cable Resistance: $R1[\Omega] \times 9$ Cable Resistance: $R2[\Omega] \times 9$</p> <p>$R3[\Omega]$: Load Resistance Distributor, etc. E1</p> <p>$0.0236 \times (R1 + R2 + R3) + 14.7 \leq E1 [V] \leq 42^{*10}$ In the case of $R3 = 250 [\Omega]$ $0.0236 \times (R1 + R2) + 20.6 \leq E1 [V] \leq 42^{*10}$</p>
<p>Pulse Output In this case, No communication is possible when a four-wire cable is used.</p>	<p>AXR Terminal</p>  <p>Cable Resistance: $R1[\Omega] \times 9$ Cable Resistance: $R2[\Omega] \times 9$</p> <p>$0.0236 \times (R1 + R2) + 14.7 \leq E2 [V] \leq 42^{*10}$</p> <p>E2 R *7 E3: 30 V DC max *1 *6 Electric counter</p> <p>*1: This supply voltage requires a power source with a maximum output current of no less than $E3/R$.</p>
<p>Pulse Output In this case, No communication is possible when a three-wire cable is used.</p>	<p>AXR Terminal</p>  <p>Cable Resistance: $R1[\Omega] \times 9$ Cable Resistance: $R2[\Omega] \times 9$</p> <p>$0.0236 \times (R1 + R2) + 14.7 \leq E4 [V] \leq 30$</p> <p>*7 R E4 *2 *6 Electric counter</p> <p>*2: This supply voltage requires a power source with a maximum output current of no less than $(E4/R + 0.0236)$.</p>
<p>Status Output Alarm Output In this case, No communication is possible when a four-wire cable is used.</p>	<p>AXR Terminal</p>  <p>Cable Resistance: $R1[\Omega] \times 9$ Cable Resistance: $R2[\Omega] \times 9$</p> <p>$0.0236 \times (R1 + R2) + 14.7 \leq E2 [V] \leq 42^{*10}$</p> <p>E2 External Power Supply 30 V DC, 120 mA max Relay AC Power Supply Magnetic valve</p>
<p>Status Output Alarm Output In this case, No communication is possible when a three-wire cable is used.</p>	<p>AXR Terminal</p>  <p>Cable Resistance: $R1[\Omega] \times 9$ Cable Resistance: $R2[\Omega] \times 9$</p> <p>$0.0236 \times (R1 + R2) + 14.7 \leq E2 [V] \leq 42^{*10}$</p> <p>E2 External Power Supply 30 V DC, 120 mA max Relay AC Power Supply Magnetic valve</p>

• Simultaneous Current-Pulse Output (General-purpose Use/Explosion Proof Type except TIIS)

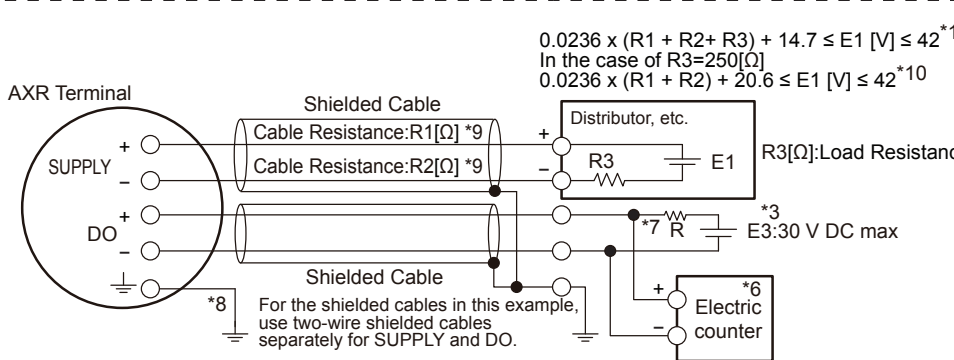
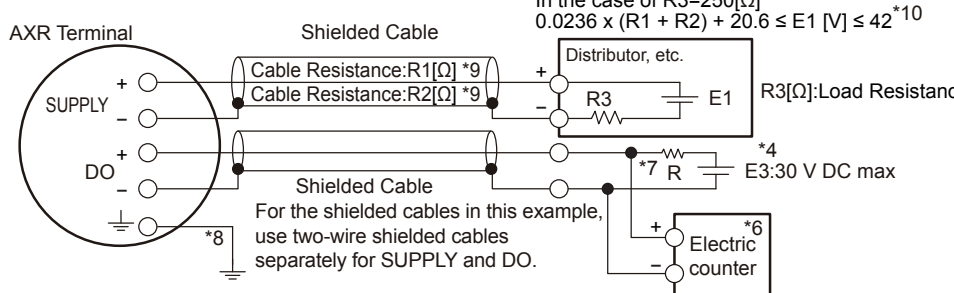
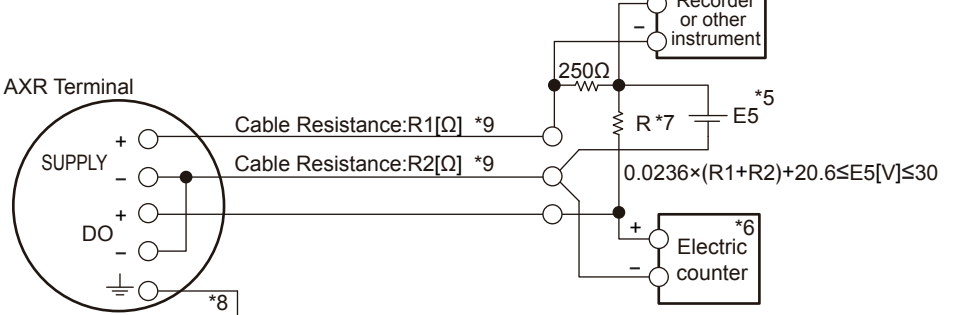
Connection	Description
<p>Simultaneous Current-Pulse Output</p> <p>Example 1 In this case, Communication is possible (up to a distance of 2 km when a CEV cable is used) and when a two-wire shielded cable is used.</p>	<p>When simultaneous output of current and pulse output are used, no communication is possible in some cases. Read the following example 1 to 3.</p>  <p> $0.0236 \times (R1 + R2 + R3) + 14.7 \leq E1 [V] \leq 42^{*10}$ In the case of $R3=250[\Omega]$ $0.0236 \times (R1 + R2) + 20.6 \leq E1 [V] \leq 42^{*10}$ </p> <p> *3: This supply voltage requires a power source with a maximum output current of no less than $E3/R$. </p>
<p>Example 2 In this case, Communication is possible (up to a distance of 2 km when a CEV cable is used) and when a one-wire shielded cable is used.</p>	 <p> $0.0236 \times (R1 + R2 + R3) + 14.7 \leq E1 [V] \leq 42^{*10}$ In the case of $R3=250[\Omega]$ $0.0236 \times (R1 + R2) + 20.6 \leq E1 [V] \leq 42^{*10}$ </p> <p> *4: This supply voltage requires a power source with a maximum output current of no less than $E3/R$. </p>
<p>Example 3 In this case, No communication is possible when a three-wire cable is used.</p>	 <p> $0.0236 \times (R1 + R2) + 20.6 \leq E5 [V] \leq 30$ </p> <p> *5: This supply voltage requires a power source with a maximum output current of no less than $(E5/R + 0.0236)$. </p>
<p>The range of load resistance R for the pulse output</p>	<p>The range of load resistance R for the pulse output must basically be 1 kΩ and 2 W. The load resistance should be selected by calculation as shown below when proper transmission is impossible due to the length of cable or frequency of pulse output.</p> $\frac{E (V)}{120} \leq R (k\Omega) \leq \frac{0.1}{C (\mu F) \times f (kHz)} \dots (1)$ $P (mW) = \frac{E^2 (V)}{R (k\Omega)} \dots (2)$ <p> E: Supply voltage (V) f: Frequency of pulse output (kHz) R: Value of load resistance (kΩ) C: Cable capacitance (μF) P: Electrical power of the load resistance (mW) Note: $C \approx 0.1 (\mu F/km)$ for CEV cable </p>

Note: • The communication is possible though it might not meet a part of the HART communication specification depending on use conditions.
 • When using current and pulse output simultaneously, the HART communication may be influenced by noise comparing analog output only.

• The Wiring Examples of Digital External Indicator Using Current Output
(General-purpose Use/Explosion Proof Type except TIIS)

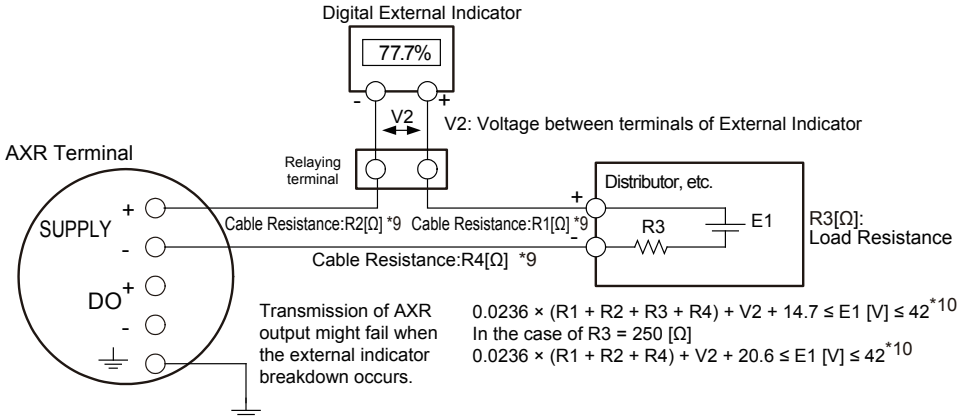
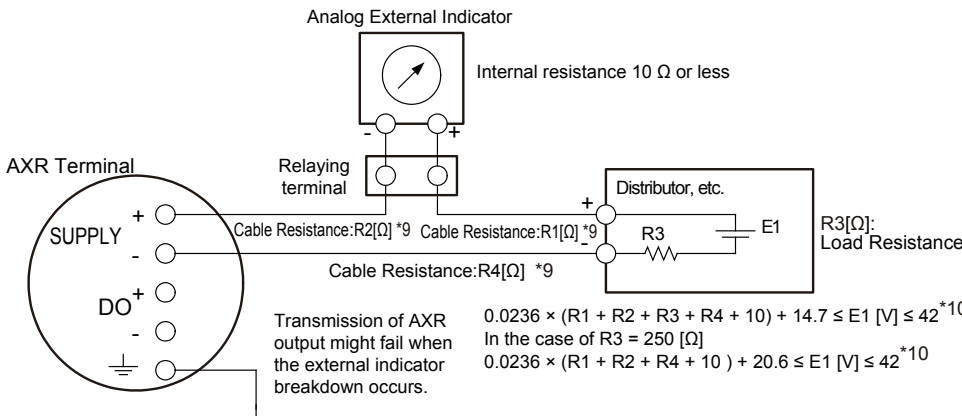
Connection	Description
<p>Current Output</p> <p>Example 1 Connection to digital external indicator</p>	 <p>Transmission of AXR output might fail when the external indicator breakdown occurs.</p> $0.0236 \times (R1 + R2 + R3 + R4) + V2 + 14.7 \leq E1 [V] \leq 42^{*10}$ $0.0236 \times (R1 + R2 + R4) + V2 + 20.6 \leq E1 [V] \leq 42^{*10}$
<p>Example 2 Connection to analog external indicator</p>	 <p>Transmission of AXR output might fail when the external indicator breakdown occurs.</p> $0.0236 \times (R1 + R2 + R3 + R4 + 10) + 14.7 \leq E1 [V] \leq 42^{*10}$ $0.0236 \times (R1 + R2 + R4 + 10) + 20.6 \leq E1 [V] \leq 42^{*10}$

*6: To avoid the influence of external noise, use an electric counter which fits to the pulse frequency.

*7: Resistor is not necessary in the case of an electric counter which can receive contact pulse signal directly.

*8: Ground the AXR to avoid the current output error in simultaneous current-pulse output.

*9: Calculate the cable resistance by using the following as a rough guideline: 10.9 Ω per 1 km for the cable with the cross section of 2 mm², 19.5 Ω per 1 km for the cable with the cross section of 1.25 mm².

*10: The maximum voltage is 32 V DC in the case of Lightning Protector specification (optional code A).

■ WIRING EXAMPLE (TIIS Explosion Proof Type)

● Current Output, Pulse Output, Status Output and Alarm Output (TIIS Explosion Proof Type)

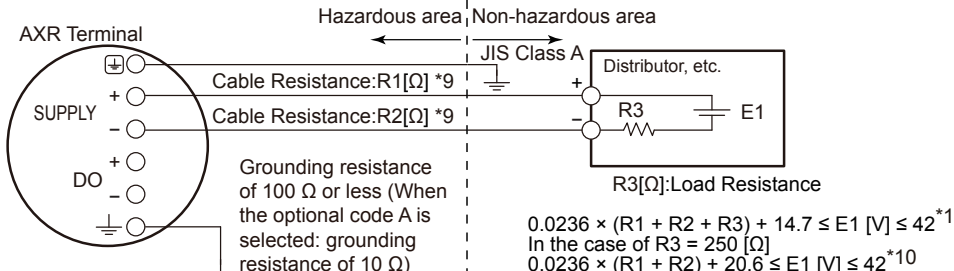
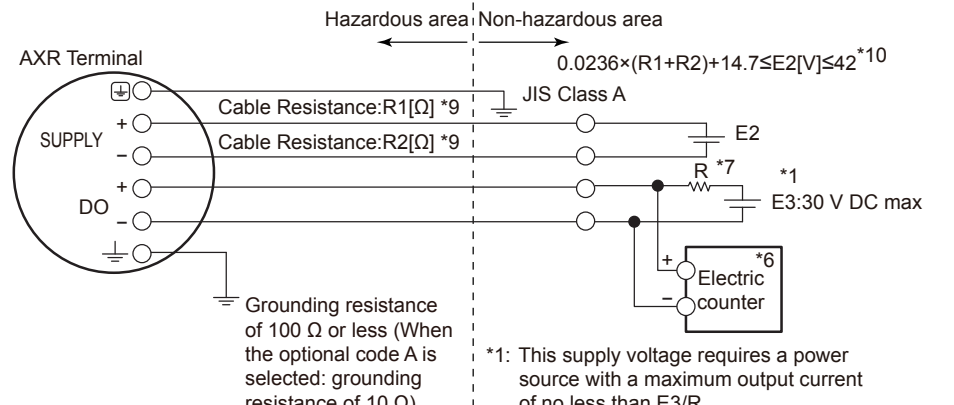
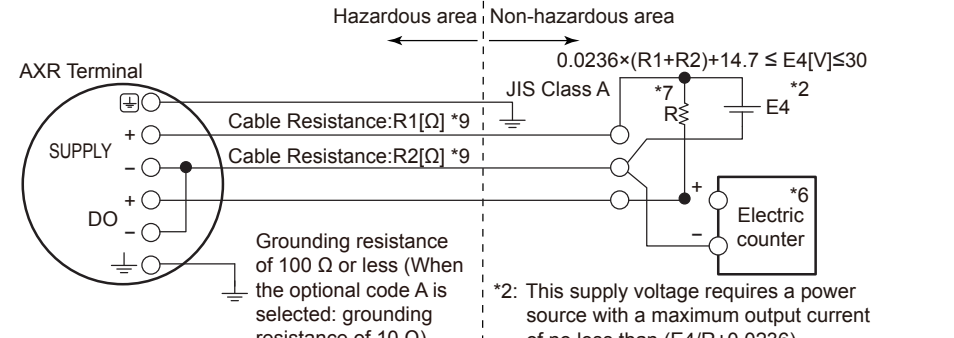
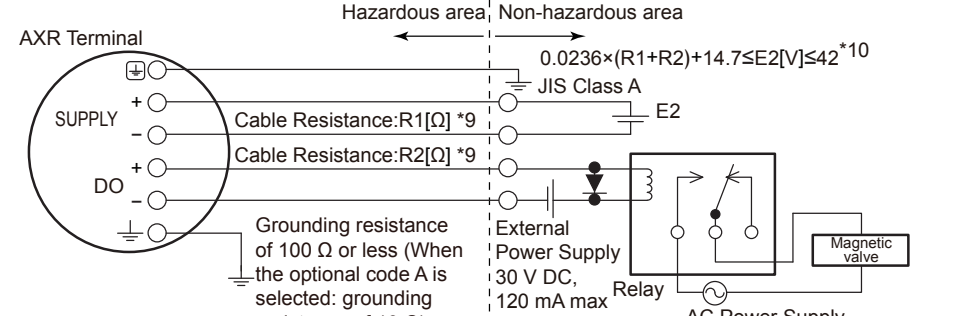
Connection	Description
<p>Current Output In this case, Communication is possible (up to a distance of 2 km when a CEV cable is used.)</p>	 <p>Hazardous area Non-hazardous area</p> <p>AXR Terminal</p> <p>Cable Resistance: $R1[\Omega] * 9$</p> <p>Cable Resistance: $R2[\Omega] * 9$</p> <p>Grounding resistance of 100 Ω or less (When the optional code A is selected: grounding resistance of 10 Ω)</p> <p>JIS Class A</p> <p>Distributor, etc.</p> <p>$R3[\Omega]$: Load Resistance</p> <p>$E1$</p> <p>$0.0236 \times (R1 + R2 + R3) + 14.7 \leq E1 [V] \leq 42^{*10}$ In the case of $R3 = 250 [\Omega]$ $0.0236 \times (R1 + R2) + 20.6 \leq E1 [V] \leq 42^{*10}$</p>
<p>Pulse Output In this case, No communication is possible when a five-wire cable is used.</p>	 <p>Hazardous area Non-hazardous area</p> <p>AXR Terminal</p> <p>Cable Resistance: $R1[\Omega] * 9$</p> <p>Cable Resistance: $R2[\Omega] * 9$</p> <p>Grounding resistance of 100 Ω or less (When the optional code A is selected: grounding resistance of 10 Ω)</p> <p>JIS Class A</p> <p>$0.0236 \times (R1 + R2) + 14.7 \leq E2 [V] \leq 42^{*10}$</p> <p>$E2$</p> <p>$R$ *7</p> <p>*1</p> <p>$E3: 30 \text{ V DC max}$</p> <p>*6</p> <p>Electric counter</p> <p>*1: This supply voltage requires a power source with a maximum output current of no less than $E3/R$.</p>
<p>Pulse Output In this case, No communication is possible when a four-wire cable is used.</p>	 <p>Hazardous area Non-hazardous area</p> <p>AXR Terminal</p> <p>Cable Resistance: $R1[\Omega] * 9$</p> <p>Cable Resistance: $R2[\Omega] * 9$</p> <p>Grounding resistance of 100 Ω or less (When the optional code A is selected: grounding resistance of 10 Ω)</p> <p>JIS Class A</p> <p>$0.0236 \times (R1 + R2) + 14.7 \leq E4 [V] \leq 30$</p> <p>$E4$</p> <p>$R$ *7</p> <p>*2</p> <p>*6</p> <p>Electric counter</p> <p>*2: This supply voltage requires a power source with a maximum output current of no less than $(E4/R + 0.0236)$.</p>
<p>Status Output Alarm Output In this case, No communication is possible when a five-wire cable is used.</p>	 <p>Hazardous area Non-hazardous area</p> <p>AXR Terminal</p> <p>Cable Resistance: $R1[\Omega] * 9$</p> <p>Cable Resistance: $R2[\Omega] * 9$</p> <p>Grounding resistance of 100 Ω or less (When the optional code A is selected: grounding resistance of 10 Ω)</p> <p>JIS Class A</p> <p>$0.0236 \times (R1 + R2) + 14.7 \leq E2 [V] \leq 42^{*10}$</p> <p>$E2$</p> <p>External Power Supply 30 V DC, 120 mA max</p> <p>Relay</p> <p>AC Power Supply</p> <p>Magnetic valve</p>

Connection	Description
<p>Status Output Alarm Output In this case, No communication is possible when a four-wire cable is used.</p>	<p>Hazardous area Non-hazardous area</p> <p>AXR Terminal</p> <p>Cable Resistance: R1[Ω] *9</p> <p>Cable Resistance: R2[Ω] *9</p> <p>Grounding resistance of 100 Ω or less (When the optional code A is selected: grounding resistance of 10 Ω)</p> <p>External Power Supply 30 V DC, 120 mA max</p> <p>AC Power Supply</p> <p>Magnetic valve</p> <p>Relay</p> <p>JIS Class A</p> <p>$0.0236 \times (R1 + R2) + 14.7 \leq E2 [V] \leq 42 * 10$</p>

• Simultaneous Current-Pulse Output (TIIS Explosion Proof Type)

Connection	Description
<p>Simultaneous Current-Pulse Output</p> <p>Example 1 In this case, Communication is possible (up to a distance of 2 km when a CEV cable is used) and when a two-wire or three-wire shielded cable is used.</p>	<p>Hazardous area Non-hazardous area</p> <p>AXR Terminal</p> <p>Shielded Cable</p> <p>Cable Resistance: R1[Ω] *9</p> <p>Cable Resistance: R2[Ω] *9</p> <p>Shielded Cable</p> <p>Grounding resistance of 100 Ω or less (When the optional code A is selected: grounding resistance of 10 Ω)</p> <p>Distributor, etc.</p> <p>R3 [Ω]: Load Resistance</p> <p>Electric counter</p> <p>JIS Class A</p> <p>$0.0236 \times (R1 + R2 + R3) + 14.7 \leq E1 [V] \leq 42 * 10$</p> <p>In the case of R3=250[Ω]</p> <p>$0.0236 \times (R1 + R2) + 20.6 \leq E1 [V] \leq 42 * 10$</p> <p>*3: This supply voltage requires a power source with a maximum output current of no less than E3/R.</p>
<p>Example 2 In this case, Communication is possible (up to a distance of 2 km when a CEV cable is used) and when a one-wire or two-wire shielded cable is used.</p>	<p>Hazardous area Non-hazardous area</p> <p>AXR Terminal</p> <p>Shielded Cable</p> <p>Cable Resistance: R1[Ω] *9</p> <p>Cable Resistance: R2[Ω] *9</p> <p>Shielded Cable</p> <p>Grounding resistance of 100 Ω or less (When the optional code A is selected: grounding resistance of 10 Ω)</p> <p>Distributor, etc.</p> <p>R3 [Ω]: Load Resistance</p> <p>Electric counter</p> <p>JIS Class A</p> <p>$0.0236 \times (R1 + R2 + R3) + 14.7 \leq E1 [V] \leq 42 * 10$</p> <p>In the case of R3=250[Ω]</p> <p>$0.0236 \times (R1 + R2) + 20.6 \leq E1 [V] \leq 42 * 10$</p> <p>*4: This supply voltage requires a power source with a maximum output current of no less than E3/R.</p>

Connection	Description
<p>Example 3 In this case, No communication is possible when a four-wire cable is used.</p>	<p style="text-align: center;">Hazardous area Non-hazardous area</p> <p style="text-align: right;">$0.0236 \times (R1 + R2) + 20.6 \leq E5 [V] \leq 30$</p> <p>AXR Terminal</p> <p>⊕</p> <p>+</p> <p>SUPPLY</p> <p>-</p> <p>+</p> <p>DO</p> <p>-</p> <p>⊖</p> <p>*8</p> <p>Cable Resistance: $R1 [\Omega]$ *9</p> <p>Cable Resistance: $R2 [\Omega]$ *9</p> <p>JIS Class A</p> <p>250Ω</p> <p>R *7</p> <p>E5</p> <p>*5</p> <p>Recorder or other instrument</p> <p>*6</p> <p>Electric counter</p> <p>*5: This supply voltage requires a power source with a maximum output current of no less than $(E5/R + 0.0236)$.</p>
<p>The range of load resistance R for the pulse output</p>	<p>The range of load resistance R for the pulse output must basically be 1 kΩ and 2 W. The load resistance should be selected by calculation as shown below when proper transmission is impossible due to the length of cable or frequency of pulse output.</p> $\frac{E (V)}{120} \leq R (k\Omega) \leq \frac{0.1}{C (\mu F) \times f (kHz)} \dots (1)$ $P (mW) = \frac{E^2 (V)}{R (k\Omega)} \dots (2)$ <p>E: Supply voltage (V) f: Frequency of pulse output (kHz) R: Value of load resistance (kΩ) C: Cable capacitance (μF) P: Electrical power of the load resistance (mW) Note: $C \approx 0.1 (\mu F/km)$ for CEV cable</p>

Note: • The communication is possible though it might not meet a part of the HART communication specification depending on use conditions.
 • When using current and pulse output simultaneously, the HART communication may be influenced by noise comparing analog output only.

• The Wiring Examples of Digital External Indicator Using Current Output (TIIS Explosion Proof Type)

Connection	Description
<p>Current Output</p> <p>Example 1 Connection to digital external indicator</p>	<p>Hazardous area Non-hazardous area</p> <p>AXR Terminal</p> <p>SUPPLY + - DO + - Ground</p> <p>JIS Class A</p> <p>Relaying terminal</p> <p>Digital External Indicator (77.7%)</p> <p>V2: Voltage between terminals of External Indicator</p> <p>Distributor, etc.</p> <p>R3 [Ω]: Load Resistance</p> <p>E1</p> <p>Cable Resistance: R2[Ω] * 9</p> <p>Cable Resistance: R1[Ω] * 9</p> <p>Cable Resistance: R4[Ω] * 9</p> <p>Grounding resistance of 100 Ω or less (When the optional code A is selected: grounding resistance of 10 Ω)</p> <p>$0.0236 \times (R1 + R2 + R3 + R4) + V2 + 14.7 \leq E1 [V] \leq 42^{*10}$</p> <p>In the case of R3 = 250 [Ω]</p> <p>$0.0236 \times (R1 + R2 + R4) + V2 + 20.6 \leq E1 [V] \leq 42^{*10}$</p>
<p>Example 2 Connection to analog external indicator</p>	<p>Hazardous area Non-hazardous area</p> <p>AXR Terminal</p> <p>SUPPLY + - DO + - Ground</p> <p>JIS Class A</p> <p>Relaying terminal</p> <p>Analog External Indicator (Internal resistance 10 Ω or less)</p> <p>Distributor, etc.</p> <p>R3 [Ω]: Load Resistance</p> <p>E1</p> <p>Cable Resistance: R2[Ω] * 9</p> <p>Cable Resistance: R1[Ω] * 9</p> <p>Cable Resistance: R4[Ω] * 9</p> <p>Grounding resistance of 100 Ω or less (When the optional code A is selected: grounding resistance of 10 Ω)</p> <p>$0.0236 \times (R1 + R2 + R3 + R4 + 10) + 14.7 \leq E1 [V] \leq 42^{*10}$</p> <p>In the case of R3 = 250 [Ω]</p> <p>$0.0236 \times (R1 + R2 + R4 + 10) + 20.6 \leq E1 [V] \leq 42^{*10}$</p>

*6: To avoid the influence of external noise, use an electric counter which fits to the pulse frequency.
 *7: Resistor is not necessary in the case of an electric counter which can receive contact pulse signal directly.
 *8: Ground the AXR to avoid the current output error in simultaneous current-pulse output.
 *9: Calculate the cable resistance by using the following as a rough guideline: 10.9 Ω per 1 km for the cable with the cross section of 2 mm², 19.5 Ω per 1 km for the cable with the cross section of 1.25 mm².
 *10: The maximum voltage is 32 V DC in the case of Lightning Protector specification (optional code A).

■ MODEL AND SUFFIX CODE

● Wafer Type

Model	Suffix Code	Description	Applicable Model
AXR025	-----	Size 25 mm (1 in.) Two-wire Magnetic Flowmeter Integral Flowmeter	
AXR040	-----	Size 40 mm (1.5 in.) Two-wire Magnetic Flowmeter Integral Flowmeter	
AXR050	-----	Size 50 mm (2 in.) Two-wire Magnetic Flowmeter Integral Flowmeter	
AXR065	-----	Size 65 mm (2.5 in.) Two-wire Magnetic Flowmeter Integral Flowmeter	
AXR080	-----	Size 80 mm (3 in.) Two-wire Magnetic Flowmeter Integral Flowmeter	
AXR100	-----	Size 100 mm (4 in.) Two-wire Magnetic Flowmeter Integral Flowmeter	
AXR150	-----	Size 150 mm (6 in.) Two-wire Magnetic Flowmeter Integral Flowmeter	
AXR200	-----	Size 200 mm (8 in.) Two-wire Magnetic Flowmeter Integral Flowmeter	
Use	G	General-Purpose Use	
	C	Explosion proof Type (*1)	
Output Signal and Communication	-D	Integral Flowmeter with 4 to 20 mA DC Output and digital communication (BRAIN protocol)	
	-E	Integral Flowmeter with 4 to 20 mA DC Output and digital communication (HART protocol) (*12)	
	-J	Integral Flowmeter with 4 to 20 mA DC Output with digital communication (HART 5/HART 7 protocol) (*13)	
Power Supply	1	Integral Flowmeter Operating voltage range 14.7 to 42 V DC Two-wire system	
Lining (*2)	A	Fluorocarbon PFA	
Electrode Material (*2)	L	JIS SUS316L (AISI 316L SS/EN 1.4404 Equivalent)	
	P	Platinum-iridium	
	H	HASTELLOY C-276 Equivalent	
	T	Tantalum	
Electrode Structure	1	Non-replaceable	
Grounding Ring and Grounding Electrode Material (*2)	N	None (*3)	
	S	JIS SUS316 (AISI 316 SS/EN 1.4401 Equivalent)	
	L	JIS SUS316L or ASTM 316L (AISI 316L SS/EN 1.4404 Equivalent)	
	P	Platinum-iridium	
	T	HASTELLOY C-276 Equivalent Tantalum	
Process Connection (*4) (*5)	-AA1	ANSI Class 150 Wafer	Size 200 mm (8.0 in.) Size 65 mm (2.5 in.) to 200 mm (8.0 in.) Size 25 mm (1.0 in.) to 50 mm (2.0 in.)
	-AA2	ANSI Class 300 Wafer	
	-AD1	DIN PN 10 Wafer (*6)	
	-AD2	DIN PN 16 Wafer (*6)	
	-AD4	DIN PN 40 Wafer (*6)	Size 80 mm (3.0 in.) to 200 mm (8.0 in.)
	-AJ1	JIS 10K Wafer	
	-AJ2	JIS 20K Wafer	
	-AG1	JIS F12 (JIS75M) Wafer	
Lay Length	1	Lay length code 1 (*7)	Size 80 mm (3.0 in.) to 200 mm (8.0 in.)
	2	Lay length code 2 (*8)	
Electrical Connection (*9)	-0	JIS G1/2 female	
	-2	ANSI 1/2 NPT female	
	-4	ISO M20 × 1.5 female	
Indicator (*10)(*11)	1	Integral Flowmeter with indicator (Horizontal)	
	2	Integral Flowmeter with indicator (Vertical)	
	N	Integral Flowmeter without indicator	
Calibration	B	Always B	
Options	/□	Optional code (Read the Table of Optional Specifications)	

*1: For explosion proof type, specify the certification type with the appropriate optional code that has the explosion proof certification approved by the certification body of each country to be used.

For the TIIS flameproof type, select optional code G11. Available only for JIS G1/2 female electrical connections.

Available only for wiring of using a flameproof packing adapter approved by Yokogawa.

The flameproof metal conduit wiring for TIIS flameproof type is not permitted.

*2:  Users must consider the characteristics of selected wetted parts material and influence of process fluids.

The use of inappropriate materials can result in the leakage of corrosive process fluids and cause injury to personnel and/or damage to plant facilities. It is also possible that the instrument itself can be damaged and that fragments from the instrument can contaminate the user's process fluids.

Be very careful with highly corrosive process fluids such as hydrochloric acid, sulfuric acid, hydrogen sulfide, sodium hypochlorite, and high-temperature steam (150°C [302°F] or above). Contact Yokogawa for detailed information of the wetted parts material.

*3: Available only for metal piping.

*4: Mating dimensions are based on standards as follow:

ANSI: ASME B 16.5, DIN: DIN 2501, JIS: JIS B 2220 and JIS G 3443-2

- *5: Allowable fluid pressure should also be limited according to fluid temperature and pressure.
- *6: Even when DIN PN10, 16, or 40 is required for a model of size 25 to 50 mm (1.0 to 2.0 in.), select PN40 (Process connection code: AD4) because there is no difference in the dimensions of the mating faces.
Even when DIN PN10 or 16 is required for a model of size 65 to 150 mm (2.5 to 6.0 in.), select PN16 (Process connection code: AD2) because there is no difference in the dimensions of the mating faces.
- *7: The dimensions of lay length code 1 are the same as those of the PFA lining standard lay length (lay length code 1) in the AXF series.
For details, read "EXTERNAL DIMENSIONS".
- *8: Excluding the size of 65 mm, dimensions of lay length code 2 are the same as those of PFA lining replacement models (lay length code 2) in AXF series. Lay lengths for special gaskets (optional codes GA, GC, GD) are different. For details, read "EXTERNAL DIMENSIONS".
- *9: For an explosion proof type except for TIIS, select "ANSI 1/2 NPT female" or "ISO M20 × 1.5 female".
For the TIIS flameproof type, select "JIS G1/2 female" and optional code G11.
- *10: Select from among the figures at the right.

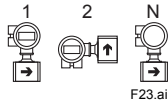

- *11: In the case of the TIIS flameproof type, select "with indicator" (code 1 or 2).
- *12: Output signal code "-E": HART 5.(Output signal code "-J" is recommended for HART communication.)
- *13: Output signal code "-J": HART 5 or HART 7 selectable. Specify HART 5 or HART 7 when ordering.

● Flange Type

Model	Suffix Code	Description	Applicable Model
AXR025 AXR040 AXR050 AXR065 AXR080 AXR100 AXR150 AXR200	----- ----- ----- ----- ----- ----- ----- -----	Size 25 mm (1 in.) Two-wire Magnetic Flowmeter Integral Flowmeter Size 40 mm (1.5 in.) Two-wire Magnetic Flowmeter Integral Flowmeter Size 50 mm (2 in.) Two-wire Magnetic Flowmeter Integral Flowmeter Size 65 mm (2.5 in.) Two-wire Magnetic Flowmeter Integral Flowmeter Size 80 mm (3 in.) Two-wire Magnetic Flowmeter Integral Flowmeter Size 100 mm (4 in.) Two-wire Magnetic Flowmeter Integral Flowmeter Size 150 mm (6 in.) Two-wire Magnetic Flowmeter Integral Flowmeter Size 200 mm (8 in.) Two-wire Magnetic Flowmeter Integral Flowmeter	
Use	G ----- C -----	General-Purpose Use Explosion proof Type (*1)	
Output Signal and Communication	-D ----- -E ----- -J -----	Integral Flowmeter with 4 to 20 mA DC Output and digital communication (BRAIN protocol) Integral Flowmeter with 4 to 20 mA DC Output and digital communication (HART protocol) (*11) Integral Flowmeter with 4 to 20 mA DC Output with digital communication (HART 5/HART 7 protocol) (*12)	
Power Supply	1 -----	Integral Flowmeter Operating voltage range 14.7 to 42 V DC Two-wire system	
Lining (*2)	A -----	Fluorocarbon PFA	
Electrode Material (*2)	L ----- P ----- H ----- T -----	JIS SUS316L (AISI 316L SS/EN 1.4404 Equivalent) Platinum-iridium HASTELLOY C-276 Equivalent Tantalum	
Electrode Structure	1 -----	Non-replaceable	
Grounding Ring and Grounding Electrode Material (*2)	N ----- S ----- L ----- P ----- H ----- T -----	None (*3) JIS SUS316 (AISI 316 SS/EN 1.4401 Equivalent) JIS SUS316L or ASTM 316L (AISI 316L SS/EN 1.4404 Equivalent) Platinum-iridium HASTELLOY C-276 Equivalent Tantalum	
Process Connection (*4) (*5)	-BA1 ----- -BA2 ----- -BD1 ----- -BD2 ----- -BD4 ----- -BJ1 ----- -BJ2 ----- -BG1 ----- -CA1 ----- -CA2 ----- -CD1 ----- -CD2 ----- -CJ1 ----- -CJ2 ----- -CG1 -----	ANSI Class 150 Flange JIS SUS304 or SUSF304 ANSI Class 300 Flange JIS SUS304 or SUSF304 DIN PN 10 Flange(JIS SUS304 or SUSF304) (*6) DIN PN 16 Flange JIS SUS304 or SUSF304 (*6) DIN PN 40 Flange JIS SUS304 or SUSF304 (*6) JIS 10K Flange JIS SUS304 or SUSF304 JIS 20K Flange JIS SUS304 or SUSF304 JIS F12 (JIS75M) Flange JIS SUS304 or SUSF304 ANSI Class 150 Flange (Carbon Steel) ANSI Class 300 Flange (Carbon Steel) DIN PN 10 Flange (Carbon Steel) (*6) DIN PN 16 Flange (Carbon Steel) (*6) JIS 10K Flange (Carbon Steel) JIS 20K Flange (Carbon Steel) JIS F12 (JIS75M) Flange (Carbon Steel)	Size 200 mm (8.0 in.) Size 65 mm (2.5 in.) to 200 mm (8.0 in.) Size 25 mm (1.0 in.) to 50 mm (2.0 in.) Size 80 mm (3.0 in.) to 200 mm (8.0 in.) Size 150 mm (6.0 in.) to 200 mm (8.0 in.), Not available for TIIS flameproof type. Size 150 mm (6.0 in.) to 200 mm (8.0 in.), Not available for TIIS flameproof type. Size 200 mm (8.0 in.), Not available for TIIS flameproof type. Size 150 mm (6.0 in.) to 200 mm (8.0 in.), Not available for TIIS flameproof type. Size 150 mm (6.0 in.) to 200 mm (8.0 in.), Not available for TIIS flameproof type. Size 150 mm (6.0 in.) to 200 mm (8.0 in.), Not available for TIIS flameproof type. Size 150 mm (6.0 in.) to 200 mm (8.0 in.), Not available for TIIS flameproof type.
Lay Length	1 -----	Lay length code 1 (*7)	
Electrical Connection (*8)	-0 ----- -2 ----- -4 -----	JIS G1/2 female ANSI 1/2 NPT female ISO M20 × 1.5 female	
Indicator (*9)(*10)	1 ----- 2 ----- N -----	Integral Flowmeter with indicator (Horizontal) Integral Flowmeter with indicator (Vertical) Integral Flowmeter without indicator	
Calibration	B ----	Always B	
Options	/□	Optional code (Read the Table of Optional Specifications)	

- *1: For explosion proof type, specify the certification type with the appropriate optional code that has the explosion proof certification approved by the certification body of each country to be used.
For the TIIS flameproof type, select optional code G11. Available only for JIS G1/2 female electrical connections.
Available only for wiring of using a flameproof packing adapter approved by Yokogawa.
The flameproof metal conduit wiring for TIIS flameproof type is not permitted.
- *2:  Users must consider the characteristics of selected wetted parts material and influence of process fluids.
The use of inappropriate materials can result in the leakage of corrosive process fluids and cause injury to personnel and/or damage to plant facilities. It is also possible that the instrument itself can be damaged and that fragments from the instrument can contaminate the user's process fluids. Be very careful with highly corrosive process fluids such as hydrochloric acid, sulfuric acid, hydrogen sulfide, sodium hypochlorite, and high-temperature steam (150°C [302°F] or above). Contact Yokogawa for detailed information of the wetted parts material.
- *3: Available only for metal piping.
- *4: Mating dimensions are based on standards as follow:
ANSI:ASME B 16.5, DIN: DIN 2501, JIS:JIS B 2220 and JIS G 3443-2
- *5: Allowable fluid pressure should also be limited according to fluid temperature and pressure.
- *6: Even when DIN PN10, 16, or 40 is required for a model of size 25 to 50 mm (1.0 to 2.0 in.), select PN40 (Process connection codes: BD4) because there is no difference in the dimensions of the mating faces.
Even when DIN PN10 or 16 is required for a model of size 65 to 150 mm (2.5 to 6.0 in.), select PN16 (Process connection codes: BD2) because there is no difference in the dimensions of the mating faces.
- *7: The dimensions of lay length code 1 are the same as those of the PFA lining standard lay length (lay length code 1) in the AXF series.
For details, read "EXTERNAL DIMENSIONS".
- *8: For an explosion proof type except for TIIS, select "ANSI 1/2 NPT female" or "ISO M20 × 1.5 female".
For the TIIS flameproof type, select "JIS G1/2 female" and optional code G11.
- *9: Select from among the figures at the right.

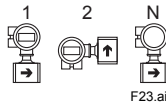

- *10: In the case of the TIIS flameproof type, select "with indicator" (code 1 or 2).
- *11: Output signal code "-E": HART 5.(Output signal code "-J" is recommended for HART communication.)
- *12: Output signal code "-J": HART 5 or HART 7 selectable. Specify HART 5 or HART 7 when ordering.

OPTIONAL SPECIFICATIONS





○ Available – : Not available

Item	Specifications	Applicable Model		Code
		General	Explosion proof	
		AXR***G	AXR***C	
Lightning Protector	A lightning protector is built into the power supply and digital output terminals. Supply voltage: 14.7 to 32 V DC Allowable current: Max 600 A (8/20 μs)	○	○	A
Down-scale of output status at alarms (Burnout)	The current output is set to 3.2 mA (-5%) or less during System Alarms (hardware failure), Process Alarms and Setting Alarms. Standard products are delivered with a setting of 21.6 mA (110%) or more during System Alarms, Process Alarms and Setting Alarms. Note: In the case of style:S1 with optional code C1, the current output is set up to 3.2 mA or less during System Alarms, and 3.8 mA during Process Alarms and Setting Alarms.	○	○	C1
Mass Unit Setting	The flow rate span, transmission pulse weight, and totalizer display pulse weight can be set in terms of mass unit. Specify the density of the process fluid when ordering in addition to the mass flow rate span, transmission pulse weight (for mass unit), and totalizer display pulse weight (for mass unit). 1. Density a. Available density Numerics: Specify the numeric within the value of 500 to 2000 kg/m ³ , 4.2 to 16.7 lb/gal, or 31.2 to 124.8 lb/cf. And it can be up to five digits, to a maximum of 32000 ignoring the decimal point. A fraction is limited to the fourth decimal place. b. Available density units: kg/m ³ , lb/gal, lb/cf Example: A water density is about 1000kg/m ³ . In this case specify “1000kg/m ³ ”. However a density is changed by temperature. Specify the actual density. (The 1000kg/m ³ is equivalent to 8.345lb/gal and 62.43lb/cf.) 2. The mass flow rate span, transmission pulse weight, and totalizer display pulse weight a. Available density Numerics: Specify the numeric within the value of 0.0001 to 32000. And it can be up to five digits, to a maximum of 32000 ignoring the decimal point. A fraction is limited to the fourth decimal place. b. Mass Units Available mass units: t, kg, g, klb, lb Available time units: /d, /h, /min, /s Note1: In the case of specifying the mass flow span, calculate the volumetric flow span by the setting density, and specify the available value in the mass flow span. Note2: In the case of transmission pulse weight and totalizer display pulse weight, specify the mass unit which was specified as the flow unit.	○	○	MU
Waterproof Glands	Waterproof glands are attached to the electrical connections. Available only for JIS G1/2 female electric connections.	○	–	EG
Waterproof Glands with Union Joints	Waterproof glands with union joints are attached to the electrical connections. Available only for JIS G1/2 female electric connections.	○	–	EU
Plastic Glands	Plastic glands are attached to the electrical connections. Available only for JIS G1/2 female electric connections.	○	–	EP
Mirror Finished PFA Lining	Mirror finishing on the PFA lining inside of the tube to the smoothness lining. The Ra is average of measured values on several points. Size 150 to 200 mm (6 to 8 in): Ra 0.05 to 0.15 μm Mirror finished PFA lining is standard for size 25 to 100 mm (1 to 4 in.) and optional for size 150 to 200 mm (6 to 8 in.) specified by optional code PM.	○	○	PM
Stainless Steel Tag Plate	A pendant tag plate of JIS SUS304 (AISI 304 SS/EN 1.4301 equivalent) is provided. Choose this option when a pendant tag plate is required in addition to the standard nameplate with the tag number inscribed on it. Dimension (Height × Width): Approx. 12.5 (4.92) × 40 (15.7) mm (inch)	○	○	SCT
Direction change of the electrical connection (*1)	+90 degrees rotated converter to change the direction of the electrical connection.	○	○	RA
	+180 degrees rotated converter to change the direction of the electrical connection.	○	○	RB
	–90 degrees rotated converter to change the direction of the electrical connection.	○	○	RC

Item	Specifications	Applicable Model		Code	
		General	Explosion proof		
		AXR***G	AXR***C		
Bolts, Nuts, and Gaskets (*2)	Bolts, nuts, and gaskets are provided for wafer connections. Available only for ANSI 150, JIS10K, or, JIS20K wafer connections.	Bolts: JIS SUS304 (AISI 304 SS stainless steel equivalent); Nuts: JIS SUS304 (AISI 304 SS stainless steel equivalent); Gaskets: Chloroprene rubber (*3)	○	○	BSC
		Bolts: JIS SUS304 (AISI 304 SS stainless steel equivalent); Nuts: JIS SUS304 (AISI 304 SS stainless steel equivalent); Gaskets: PTFE-sheathed non-asbestos (*4)	○	○	BSF
Special Gaskets (*5)	Viton gaskets for use with PVC piping. Allowable temperature and pressure are equivalent to Valqua #4010, special fluororubber not mixed.		○	○	GA
	Acid-resistant Viton gaskets for use with PVC piping. Allowable temperature and pressure are equivalent to Valqua #4010, special fluororubber mixed (mixing #D2470).		○	○	GC
	Alkali-resistant Viton gaskets for use with PVC piping. Allowable temperature and pressure are equivalent to Valqua #4010, special fluororubber mixed (mixing #D0970).		○	○	GD
Oil-prohibited Use	Electrodes, linings, and grounding rings are assembled and packed with polyethylene after being cleaned with water and acetone and dried with air. The label 'OIL FREE' is affixed.		○	○	K1
Oil-prohibited Use with Dehydrating Treatment	Electrodes, linings, and grounding rings are assembled and packed with polyethylene including desiccants after being cleaned with water and acetone and dried with air. The label 'OIL & WATER FREE' is affixed.		○	○	K5
Epoxy Resin Coating	Epoxy resin coating which has alkali-resistance instead of standard polyurethane resin coating. The color is same as standard type.		○	○	X1
High Anti-corrosion Coating	Three-layer coating (polyurethane coating on two-layer epoxy resin coating) in the same range as that for the standard coating. The color is same as standard type. Salt/alkali/acid/weather-resistance.		○	○	X2
Material Certificate	Reproduced material certificates for pipe, electrodes, grounding rings/grounding electrodes, flanges or mini flanges.		○	○	M01
Hydrostatic Test	The test verifies the absence of leaks by applying the following water pressures (which are determined under process connection conditions) to linings for ten minutes. Test results are described in a test certificate (QIC). Process Connection: Water Pressure: ANSI Class 150, DIN PN10, JIS 10K 1.5 MPa ANSI Class 300, DIN PN16, JIS 20K 3.0 MPa DIN PN40 6.0 MPa JIS F12 1.25 MPa		○	○	T01
Calibration Certificate	Level 2: The Declaration and the Calibration Equipment List are issued.		○	○	L2
	Level 3: The Declaration and the Primary Standard List are issued.		○	○	L3
	Level 4: The Declaration and the Yokogawa Measuring Instruments Control System are issued.		○	○	L4
Vent Hole	With a vent hole provided for permeable fluids (such as nitric acid, hydrofluoric acid, or sodium hydroxide at high temperature). Available only for a flange type tube.		○	○	H
Five-point Calibration in User-specified Span (*8)	A flow test near 0, 25, 50, 75, and 100% of the user-specified span is performed instead of the standard flow test and a test certificate (QIC) is submitted. Specify the span flow rate and unit when placing an order. Specify the span (100% flow span) whose corresponding flow velocity lies between 1.0 to 10 m/s and that is less than the maximum line capacity. Selectable range of flow rate span is showing below. Size: mm (in.) Selectable range of flow rate span: m ³ /h (Flow rate span velocity: m/s) 25 (1) 1.77 (1.0) to 11 (6.22) 40 (1.5) 4.53 (1.0) to 28 (6.30) 50 (2) 7.07 (1.0) to 56 (7.92) 65 (2.5) 12.0 (1.0) to 80 (6.70) 80 (3) 18.1 (1.0) to 126 (6.96) 100 (4) 28.3 (1.0) to 190 (6.72) 150 (6) 63.6 (1.0) to 380 (5.97) 200 (8) 113 (1.0) to 670 (5.92)		○	○	SC

Item	Specifications	Applicable Model		Code
		General	Explosion proof	
		AXR***G	AXR***C	
Bar-magnet for operation of magnet switches (*6)	Bar-magnet for operation of magnet switches, with a case.	○	○	BM
ATEX Certification	ATEX Explosion proof Read "HAZARDOUS AREA CLASSIFICATION"	—	○	KF2
FM Approval	FM Explosion proof Read "HAZARDOUS AREA CLASSIFICATION"	—	○	FF1
CSA Certification	CSA Explosion proof Read "HAZARDOUS AREA CLASSIFICATION"	—	○	CF1
IECEX Certification	IECEX Explosion proof Read "HAZARDOUS AREA CLASSIFICATION" In the case that final destination is Taiwan or UAE and explosion proof type is required, specify optional code SF2 (IECEX explosion proof).	—	○	SF2
TIIS Certification	TIIS flameproof Read "HAZARDOUS AREA CLASSIFICATION" (Need to select optional code G11.)	—	○	JF3
Flameproof packing adapter for TIIS Flameproof Type (*7)	One flameproof packing adapter and one blind plug.	—	○	G11
	One flameproof packing adapter addition	—	○	G32

*1:

Standard	+90-degree rotation	+180-degree rotation	-90-degree rotation
	Optional Code RA	Optional Code RB	Optional Code RC
			

*2: When the optional code BSC is specified, it is advisable to specify the optional code GA, GC, or GD at the same time to prevent potential leakage caused by the difference in elasticity between the flowtube and chloroprene gaskets.

*3: Allowable temperature and pressure with the optional code BSC (only for Gaskets: Chloroprene rubber) are equivalent to Valqua #2010.

*4: Allowable temperature and pressure with the optional code BSF (only for Gaskets: PTFE-sheathed non-asbestos) are equivalent to Valqua #7030 (S).

*5: Read description of "Gasket" in the "Wetted Part Material".
Special gaskets are inserted between the flowtube and the grounding ring or grounding electrode.

*6: Keep the bar-magnet in the case because of the powerful magnetic force.

*7: For the TIIS flameproof type, select optional code G11. In case of two flameproof packing adapters, select optional code G32 with G11. Available only for JIS G1/2 female electric connection.

*8: Standard flow test condition is follows;
- General-purpose use (25 to 200 mm)/ Explosion proof type (25 to 100 mm): span; 2 m/s, test point; 0, 30, 100%
- Explosion proof type (150, 200 mm): span; 2 m/s, test point; 0, 35, 100%

EXTERNAL DIMENSIONS

• Lay Length Code 1, AXR080-AXR100, Wafer Type

AXR080 G □ 1 A □ 1 □ - A □ □ 1
 AXR100 C □ 1 A □ 1 □ - A □ □ 1

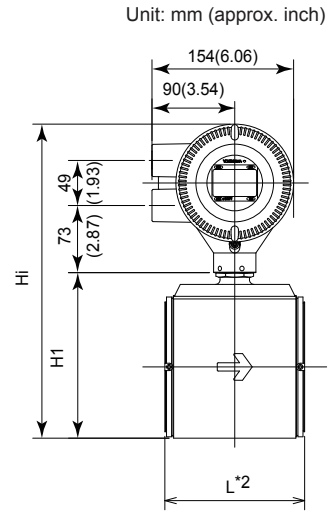
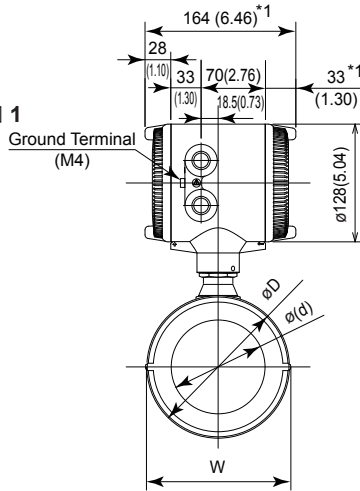

Size code		080	100
Size		80 (3)	100 (4)
Lining code		A	A
Face-to-face length	L*2	120 (4.72)	150 (5.91)
Outside dia.	øD	129 (5.08)	155 (6.10)
Inter diameter of Grounding ring	ød	77 (3.03)	102 (4.02)
Width	W	129 (5.08)	155 (6.10)
Height	H1	157 (6.18)	183 (7.20)
Max. Height	Hi	319 (12.54)	345 (13.56)
Weight kg (lb)		5.8 (12.8)	8.1 (17.9)

*1: When indicator code N is selected, subtract 5 mm (0.2 inch) from the value in the figure.
 *2: Depending on the grounding ring and the optional code, add the following value to "L" (face-to-face length).

Grounding Ring Code		S, L, H	P, T	N
Optional Code	None	+0	+26 (1.02)	-2 (0.08)
	GA, GC, GD (Special Gaskets)	+8 (0.31)	+30 (1.18)	-

F28.ai

• Lay Length Code 1, AXR150-AXR200, Wafer Type

AXR150 G □ 1 A □ 1 □ - A □ □ 1
 AXR200 C □ 1 A □ 1 □ - A □ □ 1

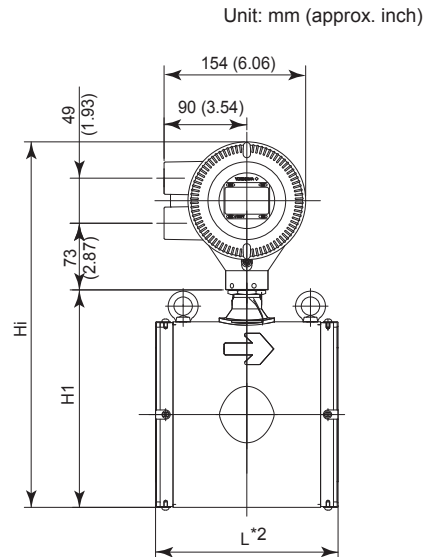
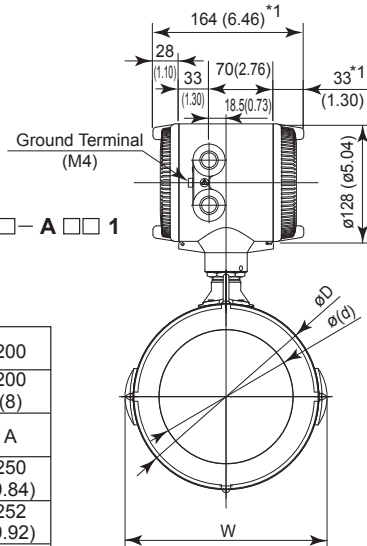

Size code		150	200
Size		150 (6)	200 (8)
Lining code		A	A
Face-to-face length	L*2	200 (7.87)	250 (9.84)
Outside dia.	øD	202 (7.95)	252 (9.92)
Inter diameter of Grounding ring	ød	146.1 (5.75)	193.6 (7.62)
Width	W	220 (8.66)	272 (10.71)
Height	H1	243 (9.57)	293 (11.54)
Max. Height	Hi	405 (15.93)	455 (17.89)
Weight kg (lb)		15.9 (35.1)	23.5 (51.8)

*1: When indicator code N is selected, subtract 5 mm (0.2 inch) from the value in the figure.
 *2: Depending on the grounding ring and the optional code, add the following value to "L" (face-to-face length).

Grounding Ring Code		S, L, H	P, T	N
Optional Code	None	+0	+32 (1.26)	-2 (0.08)
	GA, GC, GD (Special Gaskets)	+10 (0.39)	+38 (1.5)	-

F28_02.ai

● Lay Length Code 2, AXR025, Wafer Type

Unit: mm (approx. inch)

AXR025^G - □ 1 A □ 1 □ - A □ □ 2
C

Size code	025	
Size	25 (1)	
Lining code	A	
Face-to-face length	L ^{*2}	93 (3.66)
Outside dia.	øD	67.5 (2.66)
Inter diameter of Grounding ring	ød	28 (1.10)
Width	W	74.5 (2.93)
Height	H1	92 (3.62)
Max. Height	Hi	253.5 (9.98)
Weight kg (lb)	3.6 (7.8)	

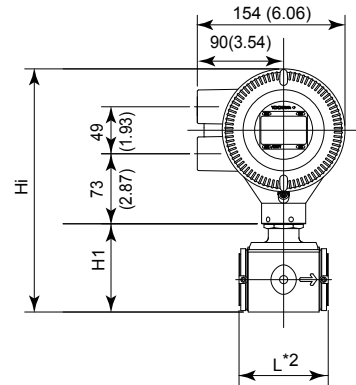
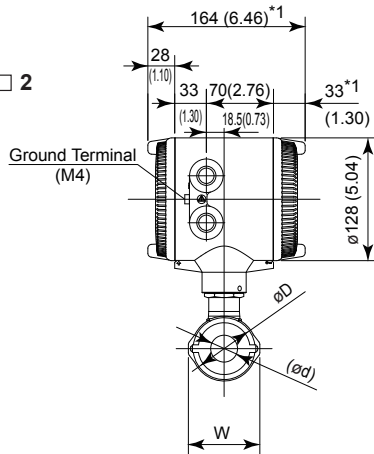

- *1: When indicator code N is selected, subtract 5 mm (0.2 inch) from the value in the figure.
- *2: Depending on the grounding ring and the optional code, add the following value to "L" (face-to-face length).

Grounding Ring Code		S, L, H	P, T	N
Optional Code	None	+0	+22 (0.87)	-2 (0.08)
	GA, GC, GD (Special Gaskets)	+8 (0.31)	+26 (1.02)	-

F29.ai

● Lay Length Code 2, AXR040-AXR065, Wafer Type

Unit: mm (approx. inch)

AXR040^G
AXR050^G - □ 1 A □ 1 □ - A □ □ 2
C
AXR065^G

Size code	040	050	065
Size	40 (1.5)	50 (2)	65 (2.5)
Lining code	A	A	A
Face-to-face length	L ^{*2}	106 (4.17)	120 (4.72)
Outside dia.	øD	86 (3.39)	117 (4.61)
Inter diameter of Grounding ring	ød	41 (1.61)	66 (2.60)
Width	W	86 (3.39)	117 (4.61)
Height	H1	111 (4.37)	147 (5.79)
Max. Height	Hi	273 (10.73)	309 (12.17)
Weight kg (lb)	4.1 (9.1)	4.8 (10.7)	5.4 (11.9)

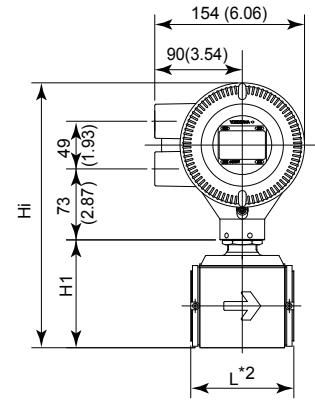
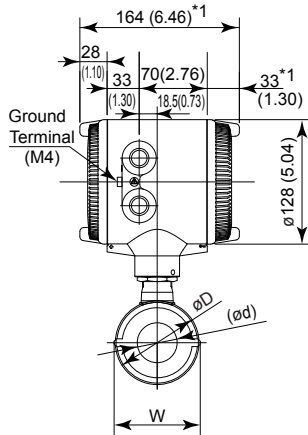

- *1: When indicator code N is selected, subtract 5 mm (0.2 inch) from the value in the figure.
- *2: Depending on the grounding ring and the optional code, add the following value to "L" (face-to-face length).

Grounding Ring Code		S, L, H	P, T	N
Optional Code	None	+0	+22 (0.87)	-2 (0.08)
	GA, GC, GD (Special Gaskets)	+8 (0.31)	+26 (1.02)	-

F30.ai

• Lay Length Code 2, AXR080-AXR100, Wafer Type

Unit: mm (approx. inch)

AXR080 G □ 1 A □ 1 □ - A □ □ 2
 AXR100 C

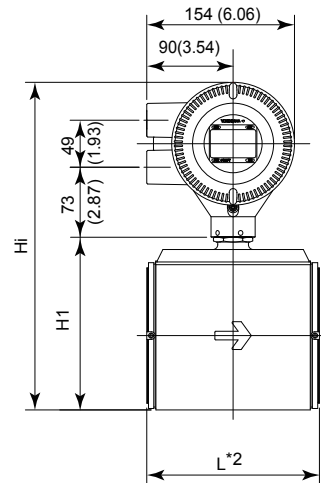
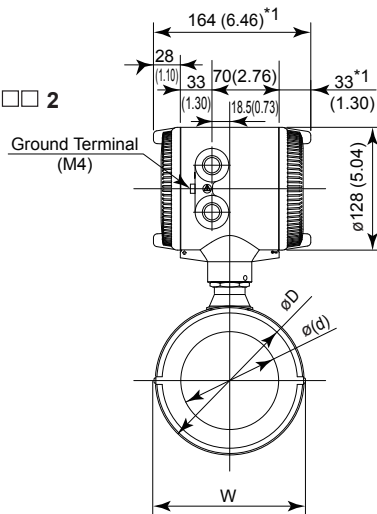

Size code		080	100
Size		80 (3)	100 (4)
Lining code		A	A
Face-to-face length	L*2	160 (6.30)	180 (7.09)
Outside dia.	øD	129 (5.08)	155 (6.10)
Inter diameter of Grounding ring	ød	77 (3.03)	102 (4.02)
Width	W	129 (5.08)	155 (6.10)
Height	H1	157 (6.18)	183 (7.02)
Max. Height	Hi	319 (12.54)	345 (13.56)
Weight kg (lb)		6.5 (14.4)	8.9 (19.6)

*1: When indicator code N is selected, subtract 5 mm (0.2 inch) from the value in the figure.
 *2: Depending on the grounding ring and the optional code, add the following value to "L" (face-to-face length).

Grounding Ring Code		S, L, H	P, T	N
Optional Code	None	+0	+22 (0.87)	-2 (0.08)
	GA, GC, GD (Special Gaskets)	+8 (0.31)	+26 (1.02)	-

F31.ai

• Lay Length Code 2, AXR150-AXR200, Wafer Type

Unit: mm (approx. inch)

AXR150G □ 1 A □ 1 □ - A □ □ 2
 AXR200C

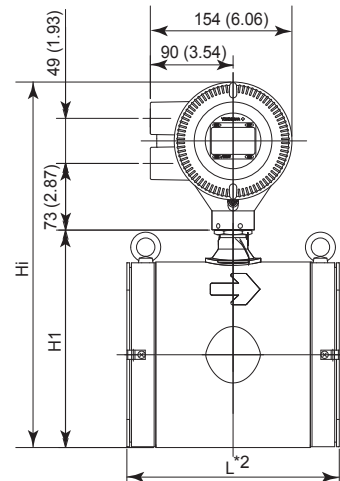
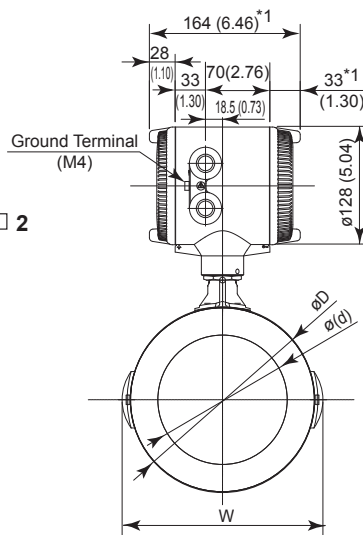

Size code		150	200
Size		150 (6)	200 (8)
Lining code		A	A
Face-to-face length	L*2	230 (9.06)	300 (11.81)
Outside dia.	øD	202 (7.95)	252 (9.92)
Inter diameter of Grounding ring	ød	140.7 (5.54)	188.9 (7.44)
Width	W	220 (8.66)	272 (10.71)
Height	H1	243 (9.57)	293 (11.54)
Max. Height	Hi	405 (15.93)	455 (17.89)
Weight kg (lb)		19.3 (42.5)	28.2 (62.2)

*1: When indicator code N is selected, subtract 5 mm (0.2 inch) from the value in the figure.
 *2: Depending on the grounding ring and the optional code, add the following value to "L" (face-to-face length).

Grounding Ring Code		S, L, H	P, T	N
Optional Code	None	+0	+28 (1.1)	-6 (0.24)
	GA, GC, GD (Special Gaskets)	+2 (0.08)	+30 (1.18)	-

F31_02.ai

● Lay Length Code 1, AXR025, JIS/ANSI/DIN Flange Type

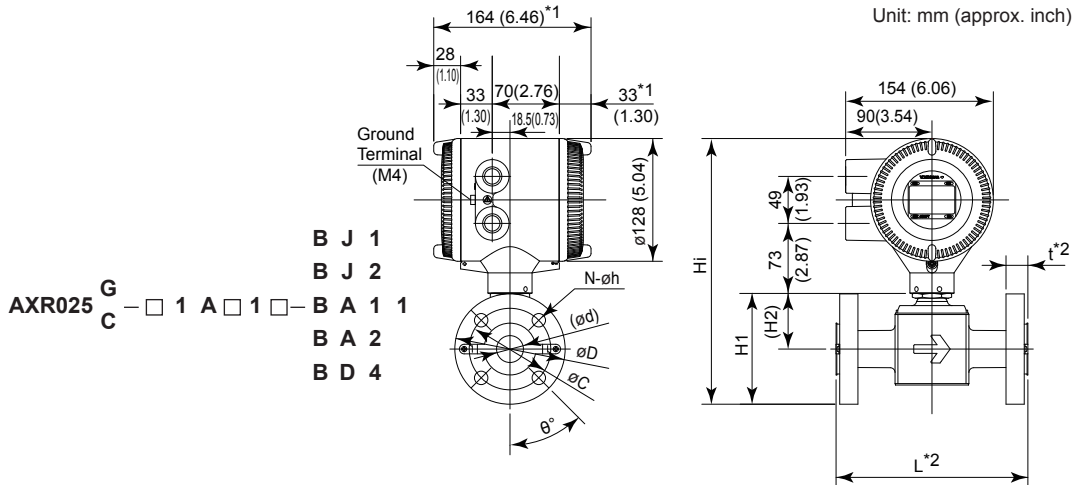

Process Connection	BJ1 (JIS10K)	BJ2 (JIS20K)	BA1 (ANSI Class 150)	BA2 (ANSI Class 300)	BD4 (DIN PN40)
Size code	025	025	025	025	025
Size	25 (1)	25 (1)	25 (1)	25 (1)	25 (1)
Lining code	A	A	A	A	A
Face-to-face length	L_{-3}^{0+2} 200 (7.87)	200 (7.87)	200 (7.87)	200 (7.87)	200 (7.87)
Outside dia.	ϕD 125 (4.92)	125 (4.92)	108.0 (4.25)	124.0 (4.88)	115 (4.53)
Thickness	t^{*2} 18 (0.71)	20 (0.79)	18.2 (0.72)	21.5 (0.85)	22 (0.87)
Inter diameter of Grounding ring	ϕd 28 (1.10)	28 (1.10)	28 (1.10)	28 (1.10)	28 (1.10)
Pitch circle dia.	ϕC 90 (3.54)	90 (3.54)	79.2 (3.12)	88.9 (3.50)	85 (3.35)
Bolt hole interval	θ° 45	45	45	45	45
Hole dia.	ϕh 19 (0.75)	19 (0.75)	15.7 (0.62)	19.1 (0.75)	14 (0.55)
Number of holes	N 4	4	4	4	4
Height	H1 120 (4.74)	120 (4.74)	112 (4.40)	120 (4.74)	115 (4.54)
Height	H2 58 (2.28)	58 (2.28)	58 (2.28)	58 (2.28)	58 (2.28)
Max. Height	Hi 282 (11.09)	282 (11.09)	273 (10.76)	281 (11.07)	277 (10.90)
Weight kg (lb)	6.1 (13.4)	6.5 (14.3)	5.6 (12.3)	6.7 (14.7)	6.4 (14.1)

*1: When indicator code N is selected, subtract 5 mm (0.2 inch) from the value in the figure.

*2: Depending on the grounding ring and the optional code, add the following value to "L" (face-to-face length) and "t" (thickness of flange).

Grounding Ring Code	L		t		L		t	
	S, L, H		P, T		N			
Optional Code	None	+0	+0	+26 (1.02)	+13 (0.51)	-2 (0.08)	-1 (0.04)	
	GA, GC, GD (Special Gaskets)	+8 (0.31)	+4 (0.16)	+30 (1.18)	+15 (0.59)	—	—	

F32.ai

• Lay Length Code 1, AXR040-AXR065, JIS/ANSI/DIN Flange Type

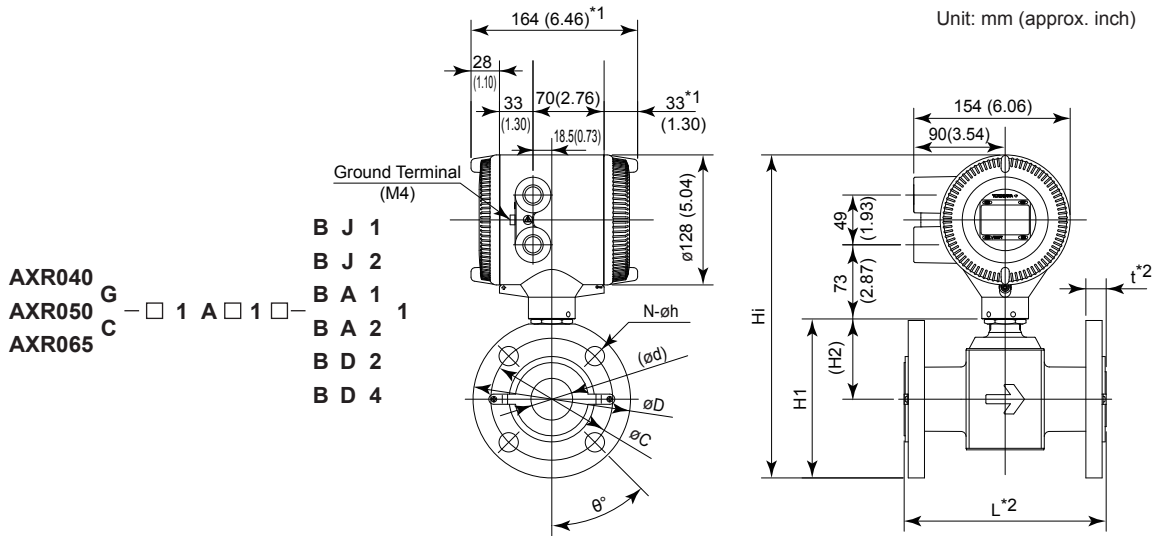

Process Connection	BJ1 (JIS10K)			BJ2 (JIS20K)			BA1 (ANSI Class 150)			BA2 (ANSI Class 300)			BD4 (DIN PN40)		BD2 (DIN PN16)	
Size code	040	050	065	040	050	065	040	050	065	040	050	065	040	050	065	
Size	40 (1.5)	50 (2)	65 (2.5)	40 (1.5)	50 (2)	65 (2.5)	40 (1.5)	50 (2)	65 (2.5)	40 (1.5)	50 (2)	65 (2.5)	40 (1.5)	50 (2)	65 (2.5)	
Lining code	A	A	A	A	A	A	A	A	A	A	A	A	A	A	A	
Face-to-face length	L_{-3}^{+2} 200 (7.87)	200 (7.87)	200 (7.87)	200 (7.87)	200 (7.87)	200 (7.87)	200 (7.87)	200 (7.87)	200 (7.87)	200 (7.87)	200 (7.87)	200 (7.87)	200 (7.87)	200 (7.87)	200 (7.87)	
Outside dia.	ϕD 140 (5.51)	155 (6.10)	175 (6.89)	140 (5.51)	155 (6.10)	175 (6.89)	127.0 (5.00)	152.4 (6.00)	177.8 (7.00)	155.4 (6.12)	165.1 (6.50)	190.5 (7.50)	150 (5.91)	165 (6.50)	185 (7.28)	
Thickness	t^{+2} 20 (0.79)	20 (0.79)	22 (0.87)	22 (0.87)	22 (0.87)	24 (0.94)	21.5 (0.85)	23.1 (0.91)	26.4 (1.04)	24.6 (0.97)	26.4 (1.04)	29.4 (1.16)	22 (0.87)	24 (0.94)	22 (0.87)	
Inter diameter of Grounding ring	ϕd 41 (1.61)	53 (2.09)	66 (2.60)	41 (1.61)	53 (2.09)	66 (2.60)	41 (1.61)	53 (2.09)	66 (2.60)	41 (1.61)	53 (2.09)	66 (2.60)	41 (1.61)	53 (2.09)	66 (2.60)	
Pitch circle dia.	ϕC 105 (4.13)	120 (4.72)	140 (5.51)	105 (4.13)	120 (4.72)	140 (5.51)	98.6 (3.88)	120.7 (4.75)	139.7 (5.50)	114.3 (4.50)	127.0 (5.00)	149.4 (5.88)	110 (4.33)	125 (4.92)	145 (5.71)	
Bolt hole interval	θ° 45	45	45	45	22.5	22.5	45	45	45	45	22.5	22.5	45	45	45	
Hole dia.	ϕh 19 (0.75)	19 (0.75)	19 (0.75)	19 (0.75)	19 (0.75)	19 (0.75)	15.7 (0.62)	19.1 (0.75)	19.1 (0.75)	22.4 (0.88)	19.1 (0.75)	22.4 (0.88)	18 (0.71)	18 (0.71)	18 (0.71)	
Number of holes	N	4	4	4	8	8	4	4	4	4	8	8	4	4	4	
Height	H1	138 (5.43)	157 (6.16)	176 (6.93)	138 (5.43)	157 (6.16)	176 (6.93)	131 (5.17)	155 (6.11)	177 (6.97)	146 (5.73)	162 (6.36)	184 (7.24)	143 (5.63)	162 (6.36)	181 (7.13)
Height	H2	68 (2.67)	79 (3.11)	89 (3.50)	68 (2.67)	79 (3.11)	89 (3.50)	68 (2.67)	79 (3.11)	89 (3.50)	68 (2.67)	79 (3.11)	89 (3.50)	68 (2.67)	79 (3.11)	89 (3.50)
Max. Height	Hi	299 (11.79)	318 (12.52)	338 (13.31)	299 (11.79)	318 (12.52)	338 (13.31)	293 (11.53)	317 (12.47)	339 (13.35)	307 (12.09)	323 (12.72)	346 (13.62)	304 (11.98)	323 (12.72)	343 (13.50)
Weight kg (lb)		7.5 (16.5)	8.7 (19.2)	11.0 (24.2)	8.0 (17.6)	8.9 (19.6)	11.3 (24.9)	7.2 (15.8)	9.3 (20.5)	12.8 (28.2)	9.6 (21.1)	10.9 (24.0)	14.6 (32.2)	8.7 (19.1)	10.6 (23.4)	11.8 (26.0)

*1: When indicator code N is selected, subtract 5 mm (0.2 inch) from the value in the figure.

*2: Depending on the grounding ring and the optional code, add the following value to "L" (face-to-face length) and "t" (thickness of flange).

Grounding Ring Code	L		t		L		t	
	S, L, H		P, T		N			
Optional Code	None	+0	+0	+26 (1.02)	+13 (0.51)	-2 (0.08)	-1 (0.04)	
	GA, GC, GD (Special Gaskets)	+8 (0.31)	+4 (0.16)	+30 (1.18)	+15 (0.59)	—	—	

F33.ai

• Lay Length Code 1, AXR080-AXR100, JIS/ANSI/DIN Flange Type

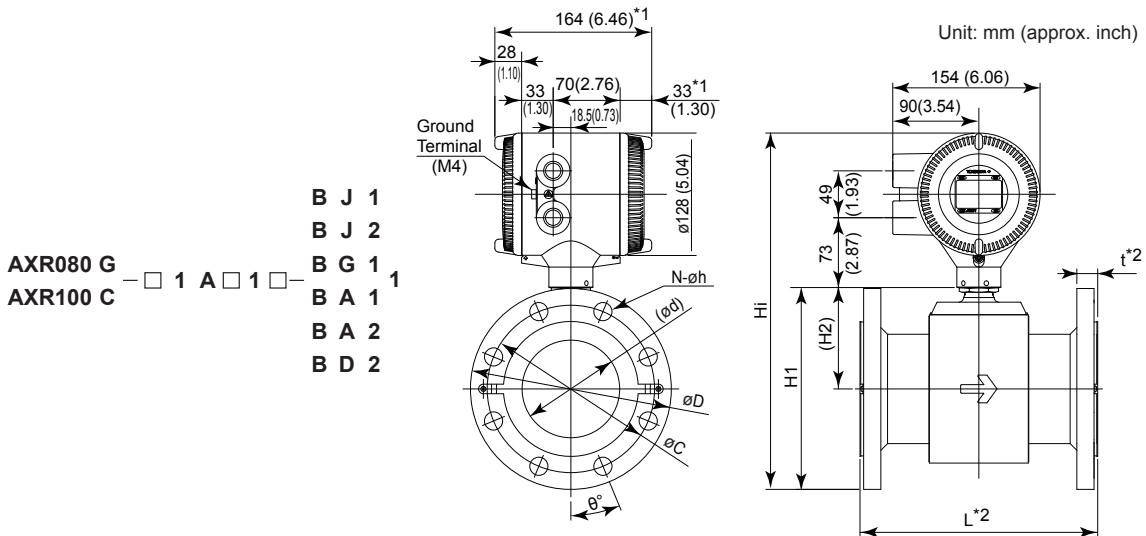

Process Connection	BJ1 (JIS10K)		BJ2 (JIS20K)		BG1 (JIS F12)		BA1 (ANSI Class 150)		BA2 (ANSI Class 300)		BD2(DIN PN16)	
Size code	080	100	080	100	080	100	080	100	080	100	080	100
Size	80 (3)	100 (4)	80 (3)	100 (4)	80 (3)	100 (4)	80 (3)	100 (4)	80 (3)	100 (4)	80 (3)	100 (4)
Lining code	A	A	A	A	A	A	A	A	A	A	A	A
Face-to-face length L ^{0*2}	200 (7.87)	250 (9.84)	200 (7.87)	250 (9.84)	200 (7.87)	250 (9.84)	200 (7.87)	250 (9.84)	200 (7.87)	250 (9.84)	200 (7.87)	250 (9.84)
Outside dia. øD	185 (7.28)	210 (8.27)	200 (7.87)	225 (8.86)	211 (8.31)	238 (9.37)	190.5 (7.50)	228.6 (9.00)	209.6 (8.25)	254.0 (10.00)	200 (7.87)	220 (8.66)
Thickness t ^{*2}	22 (0.87)	26 (1.02)	26 (1.02)	28 (1.10)	22 (0.87)	22 (0.87)	27.9 (1.10)	27.9 (1.10)	32.4 (1.28)	35.8 (1.41)	24 (0.94)	24 (0.94)
Inter diameter of Grounding ring ød	77 (3.03)	102 (4.02)	77 (3.03)	102 (4.02)	77 (3.03)	102 (4.02)	77 (3.03)	102 (4.02)	77 (3.03)	102 (4.02)	77 (3.03)	102 (4.02)
Pitch circle dia. øC	150 (5.91)	175 (6.89)	160 (6.30)	185 (7.28)	168 (6.61)	195 (7.68)	152.4 (6.00)	190.5 (7.50)	168.1 (6.62)	200.2 (7.88)	160 (6.30)	180 (7.09)
Bolt hole interval ø°	22.5	22.5	22.5	22.5	45	45	45	22.5	22.5	22.5	22.5	22.5
Hole dia. øh	19 (0.75)	19 (0.75)	23 (0.91)	23 (0.91)	19 (0.75)	19 (0.75)	19.1 (0.75)	19.1 (0.75)	22.4 (0.88)	22.4 (0.88)	18 (0.71)	18 (0.71)
Number of holes N	8	8	8	8	4	4	4	8	8	8	8	8
Height H1	187 (7.36)	211 (8.30)	195 (7.68)	218 (8.59)	200 (7.87)	225 (8.85)	190 (7.48)	220 (8.66)	200 (7.87)	233 (9.16)	195 (7.68)	216 (8.49)
Height H2	95 (3.74)	106 (4.16)	95 (3.74)	106 (4.16)	95 (3.74)	106 (4.16)	95 (3.74)	106 (4.16)	95 (3.74)	106 (4.16)	95 (3.74)	106 (4.16)
Max. Height Hi	349 (13.74)	372 (14.65)	357 (14.06)	380 (14.95)	362 (14.25)	386 (15.21)	352 (13.86)	382 (15.02)	362 (14.25)	394 (15.52)	357 (14.06)	377 (14.85)
Weight kg (lb)	11.3 (24.9)	15.2 (33.5)	14.1 (31.0)	19.7 (43.4)	13.9 (30.6)	18.3 (40.3)	14.6 (32.2)	20.5 (45.2)	18.3 (40.3)	29.6 (65.2)	13.6 (29.9)	17.3 (38.1)

*1: When indicator code N is selected, subtract 5 mm (0.2 inch) from the value in the figure.

*2: Depending on the grounding ring and the optional code, add the following value to "L" (face-to-face length) and "t" (thickness of flange).

Grounding Ring Code	L	t	L	t	L	t	
	S, L, H		P, T		N		
Optional Code	None	+0	+0	+26 (1.02)	+13 (0.51)	-2 (0.08)	-1 (0.04)
	GA, GC, GD (Special Gaskets)	+8 (0.31)	+4 (0.16)	+30 (1.18)	+15 (0.59)	—	—

• Lay Length Code 1, AXR150-AXR200, JIS/ANSI/DIN Flange Type

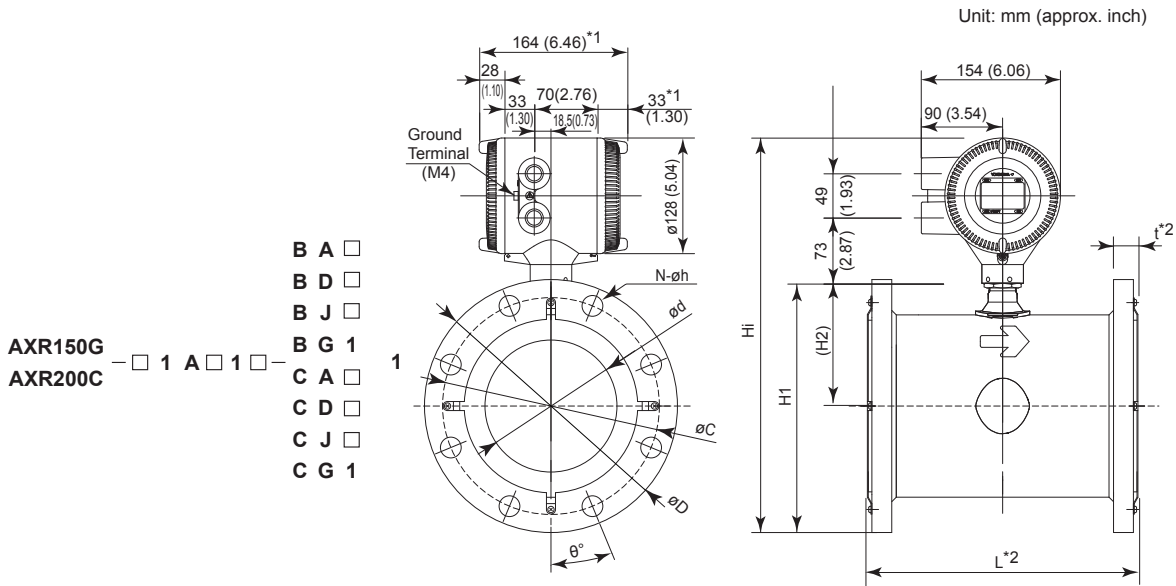

Process Connection	BJ1/CJ1 (JIS 10K)	BJ2/CJ2 (JIS 20K)	BG1/CG1 (JIS F12)	BA1/CA1 (ANSI Class 150)	BA2/CA2 (ANSI Class 300)	BD1/CD1 (DIN PN10)	BD2/CD2 (DIN PN16)
Size code	150 200	150 200	150 200	150 200	150 200	200	150 200
Size	150 (6) 200 (8)	150 (6) 200 (8)	150 (6) 200 (8)	150 (6) 200 (8)	150 (6) 200 (8)	200 (8)	150 (6) 200 (8)
Lining code	A A	A A	A A	A A	A A	A	A A
Face-to-face length L ¹ *2	300 (11.81) 350 (13.78)	300 (11.81) 350 (13.78)	300 (11.81) 350 (13.78)	300 (11.81) 350 (13.78)	300 (11.81) 350 (13.78)	350 (13.78)	300 (11.81) 350 (13.78)
Outside dia. øD	280 (11.02) 330 (12.99)	305 (12.01) 350 (13.78)	290 (11.42) 342 (13.46)	279.4 (11.00) 342.9 (13.50)	317.5 (12.50) 381.0 (15.00)	340 (13.39)	285 (11.22) 340 (13.39)
Thickness t ²	27 (1.06) 27 (1.06)	33 (1.30) 35 (1.38)	27 (1.06) 29 (1.14)	30.4 (1.20) 33.4 (1.31)	41.5 (1.63) 46.1 (1.81)	29 (1.14)	27 (1.06) 29 (1.14)
Inter diameter of Grounding ring ød	146.1 (5.75) 193.6 (7.62)	146.1 (5.75) 193.6 (7.62)	146.1 (5.75) 193.6 (7.62)	146.1 (5.75) 193.6 (7.62)	146.1 (5.75) 193.6 (7.62)	193.6 (7.62)	146.1 (5.75) 193.6 (7.62)
Pitch circle dia. øC	240 (9.45) 290 (11.42)	260 (10.24) 305 (12.01)	247 (9.72) 299 (11.77)	241.3 (9.50) 298.5 (11.75)	269.7 (10.62) 330.2 (13.00)	295 (11.61)	240 (9.45) 295 (11.61)
Bolt hole interval ø°	22.5 15	15 15	30 22.5	22.5 22.5	15 15	22.5	22.5 15
Hole dia. øh	23 (0.91) 23 (0.91)	25 (0.98) 25 (0.98)	19 (0.75) 19 (0.75)	22.4 (0.88) 22.4 (0.88)	22.4 (0.88) 25.4 (1.00)	22 (0.87)	22 (0.87) 22 (0.87)
Number of holes N	8 12	12 12	6 8	8 8	12 12	8	8 12
Height H1	281 (11.06) 331 (13.03)	294 (11.56) 341 (13.43)	286 (11.26) 337 (13.27)	281 (11.05) 337 (13.29)	300 (11.80) 357 (14.04)	336 (13.23)	284 (11.16) 336 (13.23)
Height H2	141 (5.55) 166 (6.54)	141 (5.55) 166 (6.54)	141 (5.55) 166 (6.54)	141 (5.55) 166 (6.54)	141 (5.55) 166 (6.54)	166 (6.54)	141 (5.55) 166 (6.54)
Max. Height Hi	443 (17.42) 493 (19.39)	456 (17.95) 503 (19.80)	448 (17.64) 499 (19.65)	443 (17.43) 499 (19.66)	462 (18.18) 519 (20.41)	498 (19.61)	446 (17.54) 498 (19.61)
Weight kg (lb)	29.2 (64.4) 38.7 (85.3)	38.5 (84.9) 53.3 (117.5)	31.3 (69.0) 44.6 (98.3)	32.3 (71.2) 50.6 (111.8)	80.2 (176.8) 80.2 (176.8)	43.9 (96.8)	30.1 (66.4) 43.3 (95.5)

*1: When indicator code N is selected, subtract 5 mm (0.2 inch) from the value in the figure.
 *2: Depending on the grounding ring and the optional code, add the following value to "L" (face-to-face length) and "t" (thickness of flange).

Grounding Ring Code	L		t		N		
	S, L, H	P, T	L	t	L	t	
Optional Code	None	+0	+0	+32 (1.26)	+16 (0.63)	-2 (0.08)	-1 (0.04)
	GA, GC, GD (Special Gaskets)	+10 (0.39)	+5 (0.20)	+38 (1.5)	+19 (0.75)	—	—

F34_02.ai

● Flameproof Packing Adapter for TIIS Flameproof Type (Optional code G11 or G32)

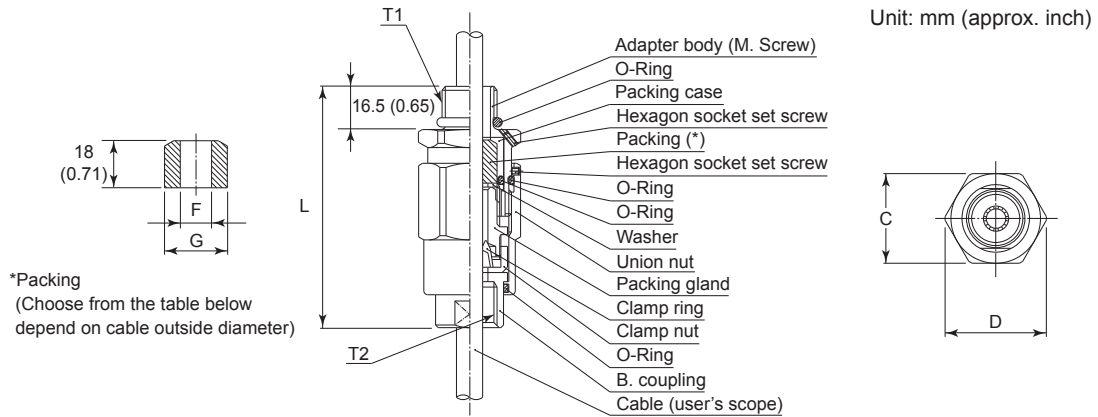

Nominal diameter		Dimension			Cable outer diameter	Packing diameter		Identification mark	Weight kg (lb)	Parts No.
T1	T2	C	D	L		F	G			
G 1/2	G 1/2	35 (1.38)	39 (1.54)	94.5 (3.72)	ø8.0 to ø10.0 (0.31 to 0.39)	ø10.0(0.39)	ø20.0 (0.79)	16 8-10	0.26 (0.57)	G9601AM*
					ø10.0 to ø12.0 (0.39 to 0.47)			16 10-12		

F35.ai
*: G 11: 1 unit
G 11 with G 32: 2 units

● Unless otherwise specified, difference in the dimensions are the following table.

General tolerance in the dimensional outline drawing.

Unit : mm (approx.inch)

Category of basic dimension		Tolerance	Category of basic dimension		Tolerance
Above	Equal or below		Above	Equal or below	
	3 (0.12)	±0.7 (±0.03)	500 (19.69)	630 (24.80)	±5.5 (±0.22)
3 (0.12)	6 (0.24)	±0.9 (±0.04)	630 (24.80)	800 (31.50)	±6.25 (±0.25)
6 (0.24)	10 (0.39)	±1.1 (±0.04)	800 (31.50)	1000 (39.37)	±7.0 (±0.28)
10 (0.39)	18 (0.71)	±1.35 (±0.05)	1000 (39.37)	1250 (49.21)	±8.25 (±0.32)
18 (0.71)	30 (1.18)	±1.65 (±0.06)	1250 (49.21)	1600 (62.99)	±9.75 (±0.38)
30 (1.18)	50 (1.97)	±1.95 (±0.08)	1600 (62.99)	2000 (78.74)	±11.5 (±0.45)
50 (1.97)	80 (3.15)	±2.3 (±0.09)	2000 (78.74)	2500 (98.43)	±14.0 (±0.55)
80 (3.15)	120 (4.72)	±2.7 (±0.11)	2500 (98.43)	3150 (124.02)	±16.5 (±0.65)
120 (4.72)	180 (7.09)	±3.15 (±0.12)			
180 (7.09)	250 (9.84)	±3.6 (±0.14)			
250 (9.84)	315 (12.40)	±4.05 (±0.16)			
315 (12.40)	400 (15.75)	±4.45 (±0.18)			
400 (15.75)	500 (19.69)	±4.85 (±0.19)			

Remarks: The numeric is based on criteria of tolerance class IT18 in JIS B 0401-1.

■ SIZING DATA (Measurable flow velocity is from 0 m/s.)

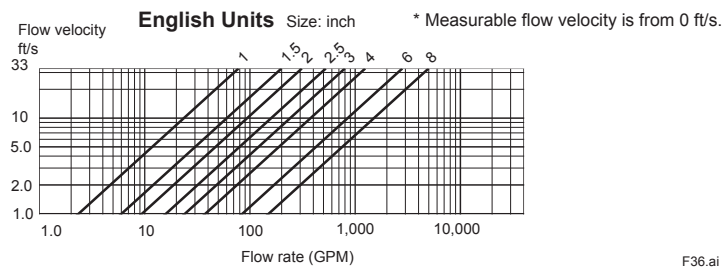
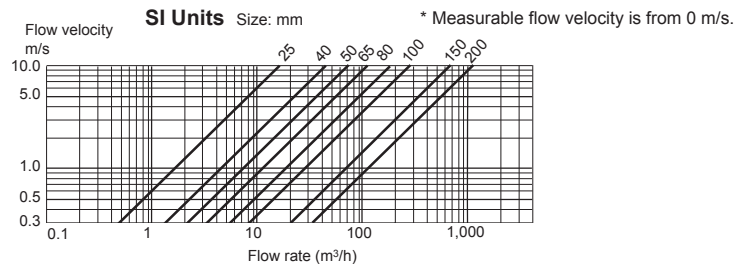

F36.ai

~~~~~ORDERING INFORMATION~~~~~

**Note 1: When ordering, the span flow rate, unit, output pulse weight, and totalizer display pulse weight can be specified. These parameters will then be set before shipment. A Tokuchu request is necessary except when these parameters are specified within the range.**

**Note 2: Some options, if ordered, require the relevant specifications to be input when ordering.**

- 1. Model, specification and optional codes
- 2. Tag No. on the nameplate and the stainless steel tag plate (optional code SCT)  
Tag No. on the nameplate and the stainless steel tag plate (Optional code SCT) can be specified by a combination of uppercase letters, lowercase letters (lower case letters is excluded for HART communication), numbers, "-" (hyphen), "." (period)", and " (space)". Specify to the "order instruction: TAG NO".  
Factory setting is blank unless otherwise specified.
- 3. Tag No. in the amplifier memory  
The characters specified by the "order instruction: TAG NO" are also written to the memory (parameter) in the amplifier. If it is necessary to specify a different tag No. only for the amplifier memory, specify the "order instruction: SOFTWARE TAG". It is also possible to specify only the "order instruction: SOFTWARE TAG".  
For the tag No. in the amplifier memory, it can be set with a combination of uppercase letters, lowercase letters (lower case letters is excluded for HART communication), numbers, "-" (hyphen)", "." (period)", and " (space)". If not specified, it will be shipped blank.  
For BRAIN protocol, up to 16 characters is set to the parameter [Tag No].  
For HART 5 protocol, up to 8 characters is set to the parameter [Tag].  
For HART 7 protocol, up to 8 characters is set to the parameter [Tag] and up to 32 characters is set to the parameter [Long tag].  
Since the "order instruction: TAG NO" can be specified only up to 16 characters, specify it to the "order instruction: Software Tag" when the customer wants to set the tag No. with more than 17 characters to the parameter [Long Tag].
- 4. Span flow rates and units  
Span flow rate can be specified numerically within the value of 0.0001 to 32000. It can be up to five digits, to a maximum of 32000 ignoring the decimal point, and a fraction is limited to the fourth decimal place.  
Specify the unit which is specified for the flow unit in the "Span Setting Function."  
The span flow rates are set to the first range in the forward direction.  
A span flow rate and its unit must be specified when the Mass Unit Setting (optional code MU) or Five-point Calibration in User-specified Span (optional code SC) is specified.

- If a span flow rate and its unit are not specified, the relevant product is delivered with the setting at 1 m/s (3.3 ft/s).
- 5. Transmission pulse weight  
If specified, a span flow rate must be set first, and then volume per pulse must be set.  
It can be specified numerically within the value from 0.0001 to 32000, and its unit must be specified in the same unit as the span flow rate.  
(Example: When "m<sup>3</sup>" is selected as "Span Flow Rate", specify "10 m<sup>3</sup>/p" as pulse weight unit.)  
Unless specified, the relevant product is delivered with the setting at 0 pulse/second.
- 6. Totalizer display pulse weight  
If specified, a span flow rate must be set first, and then volume per totalization pulse count must be set.  
It can be specified numerically within the value from 0.0001 to 32000, and its unit must be specified in the same unit as the span flow rate.  
(Example: when "m<sup>3</sup>" is selected as "Span Flow Rate", specify "10 m<sup>3</sup>/p" as pulse weight unit.)  
Unless specified, the relevant product is delivered with the setting at 0 pulse/second.
- 7. Fluid name
- 8. HART protocol revision  
When Output signal code "-J" is specified, it is mandatory to specify HART protocol revision 'HART 5' or 'HART 7'

\*\*\*-RELATED INSTRUMENTS-\*\*\*

Calibrator for Magnetic Flowmeter (AM012):  
GS 1E6K2-E  
BT200 BRAIN Terminal: GS 01C00A11-00EN  
FieldMate: GS 01R01A01-01E

\*\*\*-Reference-\*\*\*

ADMAG and AXR are registered trademarks of Yokogawa Electric Corporation.  
All other company and product names mentioned in this document are trade names, trademarks or registered trademarks of their respective companies.  
In this document, trademarks or registered trademarks are not marked with <sup>TM</sup> or <sup>®</sup>.

<Information on EU WEEE Directive>

EU WEEE (Waste Electrical and Electronic Equipment) Directive is only valid in the EU.  
This instrument is intended to be sold and used only as a part of equipment which is excluded from WEEE Directive, such as large-scale stationary industrial tools, a large-scale fixed installation and so on, and, therefore, subjected to the exclusion from the scope of the WEEE Directive. The instrument should be disposed of in accordance with local and national legislation/regulations.